



COLOR CONTROLLER E-700 INSTALLATION AND SERVICE GUIDE

**for Ricoh Aficio Color 6010, 6110
Savin SDC410, SDC410E
Gestetner CS210, CS210e
RexRotary CS810, CS810E
nashuatec CS510, CS510e
infotec 7410, 7410E
Lanier 5710 AG, 5710E AG**

A guide for service technicians

Part Number: 45016553

Copyright © 2000 Electronics For Imaging. All rights reserved.

This publication is protected by copyright, and all rights are reserved. No part of it may be reproduced or transmitted in any form or by any means for any purpose without express prior written consent from Electronics For Imaging, except as expressly permitted herein. Information in this document is subject to change without notice and does not represent a commitment on the part of Electronics For Imaging.

The software described in this publication is furnished under license and may only be used or copied in accordance with the terms of such license.

Patents: 5,867,179; 5,835,788; 5,666,436; 5,553,200; 5,543,940; 5,537,516; 5,517,334; 5,506,946; 5,424,754; 5,343,311; 5,212,546; 4,941,038; 4,837,722; 4,500,919, D406,117

Trademarks

EFI, the EFI logo, Fiery, the Fiery logo, and Rip-While-Print are trademarks registered in the U.S. Patent and Trademark Office. Fiery ZX, Fiery LX, Fiery Driven, the Fiery Driven logo, Command WorkStation, AutoCal, Starr Compression, Memory Multiplier, ColorWise, NetWise, and VisualCal are trademarks of Electronics For Imaging.

infotec and the infotec logo are trademarks of the infotec Europe B.V., which may be registered in certain jurisdictions. Adobe, the Adobe logo, Adobe Illustrator, PostScript, Adobe Photoshop, Adobe Separator, and Adobe PageMaker are registered trademarks of Adobe Systems Incorporated, registered in certain jurisdictions. EPS (Encapsulated PostScript) is a trademark of Altsys Corporation. Apple, the Apple logo, AppleShare, AppleTalk, EtherTalk, LaserWriter, and Macintosh are registered trademarks, and MultiFinder is a trademark of Apple Computer, Inc. Microsoft, MS, MS-DOS, and Windows are registered trademarks of Microsoft in the US and other countries. QuarkXPress is a registered trademark of Quark, Inc. Times, Helvetica, and Palatino are trademarks of Linotype AG and/or its subsidiaries. ITC Avant Garde, ITC Bookman, ITC Zapf Chancery, and ITC Zapf Dingbats are registered trademarks of International Typeface Corporation. Ethernet is a registered trademark of Xerox Corporation. Farallon, PhoneNET PC, and PhoneNET Talk are trademarks of Farallon Computing, Inc. COPS and COPSTalk are trademarks of CoOperative Printing Solutions, Inc. NetWare and Novell are registered trademarks and Internetwork Packet Exchange (IPX) is a trademark of Novell, Inc. SyQuest is a registered trademark, in the United States and certain other countries, of SyQuest Technology, Inc. UNIX is a registered trademark of UNIX System Laboratories, a wholly owned subsidiary of Novell, Inc. PANTONE is a registered trademark of Pantone, Inc.

All other terms and product names may be trademarks or registered trademarks of their respective owners, and are hereby acknowledged.

Legal Notices

APPLE COMPUTER, INC. ("APPLE") MAKES NO WARRANTIES, EXPRESS OR IMPLIED, INCLUDING WITHOUT LIMITATION THE IMPLIED WARRANTIES OF MERCHANTABILITY AND FITNESS FOR A PARTICULAR PURPOSE, REGARDING THE APPLE SOFTWARE. APPLE DOES NOT WARRANT, GUARANTEE, OR MAKE ANY REPRESENTATIONS REGARDING THE USE OR THE RESULTS OF THE USE OF THE APPLE SOFTWARE IN TERMS OF ITS CORRECTNESS, ACCURACY, RELIABILITY, CURRENTNESS, OR OTHERWISE. THE ENTIRE RISK AS TO THE RESULTS AND PERFORMANCE OF THE APPLE SOFTWARE IS ASSUMED BY YOU. THE EXCLUSION OF IMPLIED WARRANTIES IS NOT PERMITTED BY SOME STATES. THE ABOVE EXCLUSION MAY NOT APPLY TO YOU.

IN NO EVENT WILL APPLE, ITS DIRECTORS, OFFICERS, EMPLOYEES OR AGENTS BE LIABLE TO YOU FOR ANY CONSEQUENTIAL, INCIDENTAL OR INDIRECT DAMAGES (INCLUDING DAMAGES FOR LOSS OF BUSINESS PROFITS, BUSINESS INTERRUPTION, LOSS OF BUSINESS INFORMATION, AND THE LIKE) ARISING OUT OF THE USE OR INABILITY TO USE THE APPLE SOFTWARE EVEN IF APPLE HAS BEEN ADVISED OF THE POSSIBILITY OF SUCH DAMAGES. BECAUSE SOME STATES DO NOT ALLOW THE EXCLUSION OR LIMITATION OF LIABILITY FOR CONSEQUENTIAL OR INCIDENTAL DAMAGES, THE ABOVE LIMITATIONS MAY NOT APPLY TO YOU. Apple's liability to you for actual damages from any cause whatsoever, and regardless of the form of the action (whether in contract, tort [including negligence], product liability or otherwise), will be limited to \$50.

Restricted Rights Legends

For defense agencies: Restricted Rights Legend. Use, reproduction, or disclosure is subject to restrictions set forth in subparagraph (c)(1)(ii) of the Rights in Technical Data and Computer Software clause at 252.227.7013.

For civilian agencies: Restricted Rights Legend. Use, reproduction, or disclosure is subject to restrictions set forth in subparagraph (a) through (d) of the commercial Computer Software Restricted Rights clause at 52.227-19 and the limitations set forth in Electronics For Imaging's standard commercial agreement for this software. Unpublished rights reserved under the copyright laws of the United States.

Printed in the United States of America on recycled paper.

FCC Information

WARNING: FCC Regulations state that any unauthorized changes or modifications to this equipment not expressly approved by the manufacturer could void the user's authority to operate this equipment.

Class B Declaration of Conformity

This equipment has been tested and found to comply with the limits for a class B digital device, pursuant to Part 15 of the FCC rules. These limits are designed to provide reasonable protection against harmful interference in a residential installation. This equipment generates, uses and can radiate radio frequency energy and if not installed and used in accordance with the instructions, may cause harmful interference to radio communications. However, there is no guarantee that interference will not occur in a particular installation.

If this equipment does cause harmful interference to radio or television reception, which can be determined by turning the equipment off and on, the user is encouraged to try to correct the interference by one or more of the following measures:

Reorient or relocate the receiving antenna.

Increase the separation between the equipment and receiver.

Connect the equipment into an outlet on a circuit different from that to which the receiver is connected.

Consult the dealer or an experienced radio/TV technician for help.

In order to maintain compliance with FCC regulations, shielded cables must be used with this equipment. Operation with non-approved equipment or unshielded cables is likely to result in interference to radio and TV reception. The user is cautioned that changes and modifications made to the equipment without the approval of manufacturer could void the user's authority to operate this equipment.

Industry Canada Class B Notice

This Class B digital apparatus meets all the requirements of the Canadian Interference-Causing Equipment Regulations.

Avis de Conformation Classe B de l'Industrie Canada

Cet appareil numérique de la classe B respecte toutes les exigences du Règlement sur le matériel brouilleur du Canada.

RFI Compliance Notice

This equipment has been tested concerning compliance with the relevant RFI protection requirements both individually and on system level (to simulate normal operation conditions). However, it is possible that these RFI Requirements are not met under certain unfavorable conditions in other installations. It is the user who is responsible for compliance of his particular installation.

Dieses Gerat wurde einzeln sowohl als auch in einer Anlage, die einen normalen Anwendungsfall nachbildet, auf die Einhaltung der Funk-entstoerbestimmungen geprueft. Es ist jedoch moeglich, dass die Funk-entstoerbestimmungen unter unguenstigen Umstaenden bei anderen Geratekombinationen nicht eingehalten werden. Fuer die Einhaltung der Funk-entstoerbestimmungen seigner gesamten Anlage, in der dieses Gerat betrieben wird, ist der Betreiber verantwortlich.

Compliance with applicable regulations depends on the use of shielded cables. It is the user who is responsible for procuring the appropriate cables.

Einhaltung mit betreffenden Bestimmungen kommt darauf an, dass geschirmte Ausfuehrungen gebraucht werden. Fuer die beschaffung richtiger Ausfuehrungen ist der Betreiber verantwortlich.

Software License Agreement

Before using the Software, please carefully read the following terms and conditions. BY USING THIS SOFTWARE, YOU SIGNIFY THAT YOU HAVE ACCEPTED THE TERMS OF THIS AGREEMENT. If you cannot or do not accept these terms, you may return the entire package within ten (10) days to the Distributor or Dealer from which you obtained them for a full refund.

Electronics For Imaging grants to you a non-exclusive, non-transferable license to use the software and accompanying documentation ("Software") included with the E-700 you have purchased, including without limitation the PostScript® software provided by Adobe Systems Incorporated.

You may:

- a. use the Software solely for your own customary business purposes and solely with E-700;
- c. use the trademarks used by Electronics For Imaging to identify the Coded Font Programs and Typefaces reproduced therefrom ("Trademarks"); and
- d. assign your rights under this Agreement to a transferee of all of your right, title and interest in and to E-700 provided the transferee agrees to be bound by all of the terms and conditions of this Agreement.

You may not:

- a. make use of the Software, directly or indirectly, to print bitmap images with print resolutions of 600 dots per inch or greater, or to generate fonts or typefaces for use other than with E-700;
- b. make or have made, or permit to be made, any copies of the Software, Coded Font Programs, accompanying documentation or portions thereof, except as necessary for use with the E-700 unit purchased by you; provided, however, that under no circumstances may you make or have made, or permit to be made, any copies of that certain portion of the Software which has been included on the E-700 hard disk drive. You may not copy the documentation;
- c. attempt to alter, disassemble, decrypt or reverse engineer the Software, Coded Font Programs or accompanying documentation.
- d. rent or lease the Software.

Proprietary Rights

You acknowledge that the Software, Coded Font Programs, Typefaces, Trademarks and accompanying documentation are proprietary to Electronics For Imaging and its suppliers and that title and other intellectual property rights therein remain with Electronics For Imaging and its suppliers. Except as stated above, this Agreement does not grant you any right to patents, copyrights, trade secrets, trademarks (whether registered or unregistered), or any other rights, franchises or licenses in respect of the Software, Coded Font Programs, Typefaces, Trademarks or accompanying documentation. You may not adapt or use any trademark or trade name which is likely to be similar to or confusing with that of Electronics For Imaging or any of its suppliers or take any other action which impairs or reduces the trademark rights of Electronics For Imaging or its suppliers. The trademarks may only be used to identify printed output produced by the Coded Font Programs. At the reasonable request of Electronics For Imaging, you must supply samples of any Typeface identified with a trademark.

The MacApp software is proprietary to Apple Computer, Inc. and is licensed to Electronics For Imaging for distribution only for use in combination with Fiery software utilities.

Confidentiality

You agree to hold the Software and Coded Font Programs in confidence, disclosing the Software and Coded Font Programs only to authorized users having a need to use the Software and Coded Font Programs as permitted by this Agreement and to take all reasonable precautions to prevent disclosure to other parties.

Remedies

Unauthorized use, copying or disclosure of the Software, Coded Font Programs, Typefaces, Trademarks or accompanying documentation will result in automatic termination of this license and will make available to Electronics For Imaging other legal remedies.

Limited Warranty And Disclaimer

Electronics For Imaging warrants that, for a period of ninety (90) days from the date of delivery to you, the Software under normal use will perform without significant errors that make it unusable. Electronics For Imaging's entire liability and your exclusive remedy under this warranty (which is subject to you returning E-700 to Electronics For Imaging or an authorized dealer) will be, at Electronics For Imaging's option, to use reasonable commercial efforts to attempt to correct or work around errors, to replace the Software with functionally equivalent software, or to refund the purchase price and terminate this Agreement. Some states do not allow limitations on duration of implied warranty, so the above limitation may not apply to you.

Except for the above express limited warranty, Electronics For Imaging makes and you receive no warranties or conditions on the Products, express, implied, or statutory, and Electronics For Imaging specifically disclaims any implied warranty or condition of merchantability or fitness for a particular purpose.

For warranty service, please contact your authorized service/support center.

EXCEPT FOR THE ABOVE EXPRESS LIMITED WARRANTY, ELECTRONICS FOR IMAGING MAKES AND YOU RECEIVE NO WARRANTIES OR CONDITIONS ON THE SOFTWARE OR CODED FONT PROGRAMS, EXPRESS, IMPLIED, STATUTORY, OR IN ANY OTHER PROVISION OF THIS AGREEMENT OR COMMUNICATION WITH YOU, AND ELECTRONICS FOR IMAGING SPECIFICALLY DISCLAIMS ANY IMPLIED WARRANTY OR CONDITION OF MERCHANTABILITY OR FITNESS FOR A PARTICULAR PURPOSE. Electronics For Imaging does not warrant that the operation of the software will be uninterrupted or error free or that the Software will meet your specific requirements.

Limitation Of Liability

IN NO EVENT WILL ELECTRONICS FOR IMAGING OR ITS SUPPLIERS BE LIABLE FOR ANY DAMAGES, INCLUDING LOSS OF DATA, LOST PROFITS, COST OF COVER OR OTHER SPECIAL, INCIDENTAL, CONSEQUENTIAL OR INDIRECT DAMAGES ARISING FROM THE USE OF THE SOFTWARE, CODED FONT PROGRAMS OR ACCOMPANYING DOCUMENTATION, HOWEVER CAUSED AND ON ANY THEORY OF LIABILITY. THIS LIMITATION WILL APPLY EVEN IF ELECTRONICS FOR IMAGING OR ANY AUTHORIZED DEALER HAS BEEN ADVISED OF THE POSSIBILITY OF SUCH DAMAGE. YOU ACKNOWLEDGE THAT THE PRICE OF THE UNIT REFLECTS THIS ALLOCATION OF RISK. BECAUSE SOME STATES/JURISDICTIONS DO NOT ALLOW THE EXCLUSION OR LIMITATION OF LIABILITY FOR CONSEQUENTIAL OR INCIDENTAL DAMAGES, THE ABOVE LIMITATION MAY NOT APPLY TO YOU.

Export Controls

You agree that you will not export or re-export the Software or Coded Font Programs in any form without the appropriate United States and foreign government licenses. Your failure to comply with this provision is a material breach of this Agreement.

Government Use

Use, duplication or disclosure of the Software by the United States Government is subject to restrictions as set forth in subdivision (c) (1) (ii) of the Rights in Technical Data and Computer Software clause at DFARS 252.227-7013 or in subparagraphs (c) (1) and (2) of the Commercial Computer Software—Restricted Right Clause at 48 CFR 52.227-19, as applicable.

Third Party Beneficiary

You are hereby notified that Adobe Systems Incorporated, a California corporation located at 345 Park Avenue, San Jose, CA 95110-2704 USA (“Adobe”) is a third-party beneficiary to this Agreement to the extent that this Agreement contains provisions which relate to your use of the Fonts, the Coded Font Programs, the Typefaces and the Trademarks licensed hereby. Such provisions are made expressly for the benefit of Adobe and are enforceable by Adobe in addition to Electronics For Imaging.

General

This Agreement will be governed by the laws of the State of California.

This Agreement is the entire agreement held between us and supersedes any other communications or advertising with respect to the Software, Coded Font Programs and accompanying documentation.

If any provision of this Agreement is held invalid, the remainder of this Agreement shall continue in full force and effect.

If you have any questions concerning this Agreement, please write to Electronics For Imaging, Attn: Licensing Dept. or see Electronics For Imaging’s web site at www.efi.com.

Electronics For Imaging
303 Velocity Way
Foster City, CA 94404

Contents

Preface

About this guide	xi
About the illustrations in this guide	xi
Terminology and conventions	xii
Precautions	xiii
Tools you will need	xiv

Chapter 1: Introduction

Features	1-1
How the E-700 operates	1-2
E-700 print options	1-3
User software	1-3
Fiery WebTools	1-4

Chapter 2: Installation

Setting customer expectations	2-1
Unpacking the E-700	2-2
Preparing for installation	2-3
Opening the copier	2-3
Installing the E-700 in the copier	2-5
Reassembling the copier	2-6
Initial startup	2-7
Printing a Test Page	2-8
Printing the Configuration page	2-9
Connecting the E-700 to the network	2-10
Ethernet network connection	2-10

Chapter 3: Using the E-700 Operation Panel

Overview	3-1
Keys	3-2
Activity indicators	3-2
Screens	3-3
Functions screen	3-4
Startup screen	3-5

Contents

Chapter 4: Service Procedures

Overview	4-1
Accessing the E-700	4-3
Checking E-700 internal connections	4-5
Replacing parts of the E-700	4-7
E-700 board	4-8
Video interface board	4-12
SCSI interface board	4-14
DIMMs	4-15
Battery	4-16
CPU fan	4-17
Exhaust fan	4-18
Hard disk drive	4-19
Restoring E-700 functionality after service	4-22
E-700 system software	4-24
System software installation reminders	4-24
Installing system software using the SCSI interface connector	4-25

Chapter 5: Troubleshooting Procedures

The troubleshooting process	5-1
Where problems occur	5-2
Before you go to the customer site	5-3
Preliminary on-site checkout	5-4
Checking connections	5-4
General E-700 system errors	5-5
Video board diagnostics	5-7
Printing the Test Page	5-8
Checking network connections	5-9
Printing to the E-700	5-10
General printing problems	5-11

Contents

Appendix A: Specifications

Hardware features	A-1
Networking and connectivity	A-1
User software	A-1
Safety and emissions compliance	A-1
Output voltage	A-2

Appendix B: Controller Interface Type F

Installation Procedure	B-1
------------------------	-----

Index

About this guide

Preface

The *Installation and Service Guide* is intended for certified Color Controller E-700 and copier service technicians. If you have not received certification, you should not attempt to install or service the E-700. Electronics For Imaging does not warrant the performance of the E-700 if installed or serviced by non-certified personnel.

About this guide

This guide is divided into the following sections:

- “Preface”
Gives general information about this guide and general information that you should know before you attempt to install or service the E-700.
- Chapter 1, “Introduction.”
Provides general information about the E-700.
- Chapter 2, “Installation.”
Provides detailed instructions for installing the E-700 into the copier.
- Chapter 3, “Using the E-700 Operation Panel.”
Describes the E-700 Operation Panel and how to use it.
- Chapter 4, “Service Procedures.”
Describes removal and replacement procedures for E-700 components.
- Chapter 5, “Troubleshooting Procedures.”
Identifies the source of common problems and suggests ways of correcting them.
- Appendix A, “Specifications.”
Summarizes the hardware and networking features of the E-700 controller.
- Appendix B, “Controller Interface Type F.”
Reprints the Installation Procedure for the Controller Interface Type F kit, which must be installed before installing the E-700.

Customers should not use the technical service documentation. Do not leave this guide behind after you make a service call.

About the illustrations in this guide

Illustrations in this guide reflect the E-700 at the time of publication. Components shown in these illustrations are subject to change. To receive information about any components that do not match illustrations in this guide, contact your authorized service/support center.

Preface

Terminology and conventions

The term copier refers to the following copiers in which the Controller Interface Type F kit and the E-700 Controller kit are installed:

Copier	Basic Auto-Duplex Model (A257)	Edit Auto-Duplex Model (A269)
Ricoh	Aficio Color 6010	Aficio Color 6110
Savin	SDC410	SDC410E
Gestetner	CS210	CS210e
RexRotary	CS810	CS810E
nashuatec	CS510	CS510e
infotec	7410	7410E
Lanier	5710 AG	5710E AG

The term “network administrator” refers to the person responsible for maintaining the network at the customer site.

The term “Fiery Operation Panel” describes the area within the copier Operation Panel that is dedicated to the E-700 printer controller. It includes the display window and the surrounding keys and activity lights.

The term “PC” refers to any IBM PC or compatible computer running Windows over MS-DOS.

The term “E-700 board” refers to the E-700 printer controller (the main board in the E-700).

The term “100BaseT” is used throughout this manual to refer to 100BaseTX.

The term “HDD” refers to the hard disk drive that is part of the E-700 assembly.

The term “I/F unit” refers to the portion of the controller interface kit that houses the E-700. See the *Controller Interface Type F Installation Procedure* for more information. This document is included in Appendix B, “Controller Interface Type F.”

NOTE: The note indicator highlights important messages and additional information.



The caution icon indicates a need for special care and safety when handling the equipment.

Precautions

Precautions

Always observe the following general precautions when installing and servicing the E-700:

1. Report any shipping damage.

If there is any evidence of shipping or handling damage to packing boxes or their contents, save the damaged boxes and parts, call the shipper immediately to file a claim, and notify your authorized service/support center.

2. Never alter an existing network without permission.

The E-700 probably connects to an existing Local Area Network (LAN) based on Ethernet hardware. The network is the link between the customer's computer, existing laser printers, and other prepress equipment. Never disturb the LAN by breaking or making a network connection, altering termination, installing or removing networking hardware or software, or shutting down networked devices without the knowledge and express permission of the network administrator.

3. Never enter an IP address in Network Setup.

Only the network administrator should enter an IP address on a network device. Assigning an incorrect IP address to the E-700 can cause unpredictable errors on any or all devices.

4. Follow standard ESD (electrostatic discharge) precautions while working on the internal components of the copier.

Static is always a concern when servicing electronic devices. It is highly unlikely that the area around the copier is static-free. Carpeting, leather-soled shoes, synthetic clothing fibers, silks, and plastics may generate a static charge of more than 10,000 volts. Static discharge is capable of destroying the circuits etched in silicon microchips, or dramatically shortening their life span. By observing standard precautions, you may avoid extra service calls and save the cost of a new board.

When possible, work on a ground-connected antistatic mat. Wear an antistatic wristband, grounded at the same place as the antistatic mat. If that is not possible:

- Attach a grounding strap to your wrist. Attach the other end to a good ground.
- When you remove an electronic component, place it into an antistatic bag immediately. Do not walk across a carpet or vinyl floor while carrying an unprotected board.
- Leave new electronic components inside their antistatic bags until you are ready to install them.
- When you unpack the electronic components, touch a metal area of the copier to discharge the static on your body. Place the components on a grounded antistatic surface, component-side up.

Preface

5. **Avoid flexing printed circuit boards and handle them by opposing edges (not corners) only.**
6. **Never set a cup of coffee—or any liquid—on or near any components or the copier.**

Tools you will need

To service the E-700, you should bring the following:

- ESD wrist grounding strap
- Antistatic mat
- #0, #1, and #2 Phillips head screwdrivers (non-magnetic)
- 3/16" hex nut driver (recommended)
- Small flat-blade screwdriver (non-magnetic)
- Small needlenose pliers
- Flashlight
- This guide and any technical notes you may have for the E-700.

1 Features

Chapter 1: Introduction

The E-700 is a high performance embedded color controller that provides computer connectivity and highly efficient color printing capability to digital color copiers. It is optimized for high-speed communications, processing, rasterization, and printing of continuous tone color and monochrome (black and white) pages. Users can print from networked Mac OS computers, from networked PCs running Windows NT, Windows 95/98, Windows 2000, and from UNIX workstations.

Features

As an integral part of the printing system, the E-700 enables users to:

- Send images over AppleTalk, TCP/IP, and Novell networks.
- Spool print jobs and select a printing priority for each job. Users can control spooled print jobs sent to the E-700 with user software running on networked Mac OS computers and PCs.
- Print files in color, grayscale, and black and white.
- Use PostScript fonts. The customer can download additional fonts, as needed.
- Use built-in ColorWise™ color management and NetWise™ networking features.

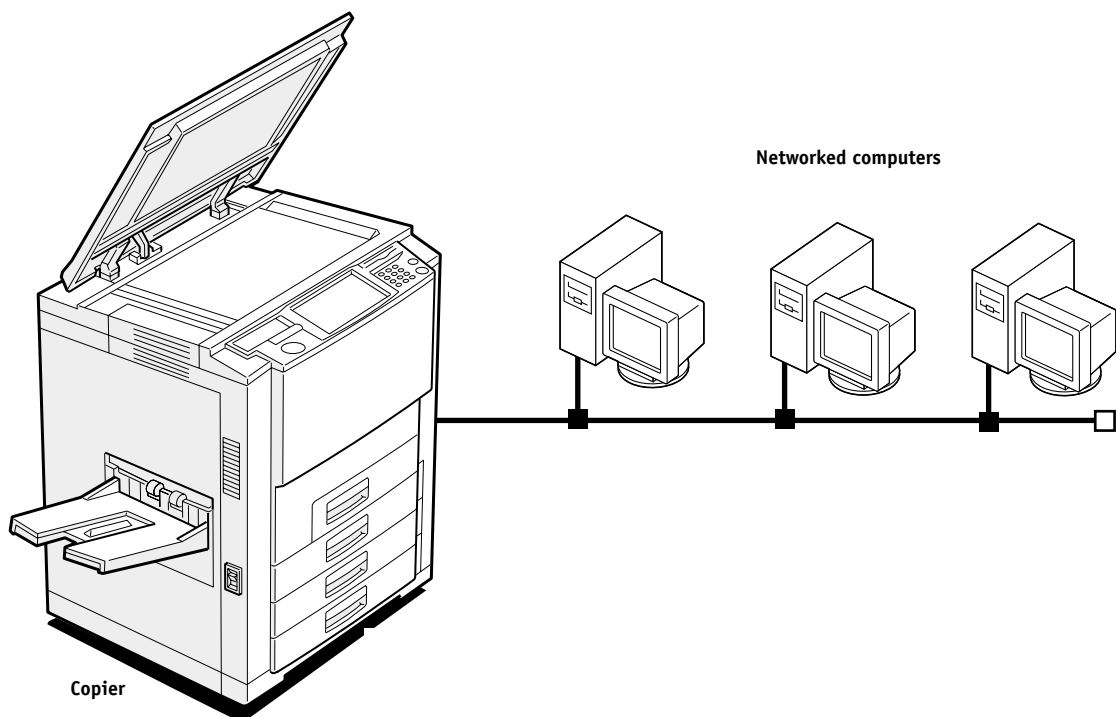

FIGURE 1-1 E-700 printing system

1 Introduction

How the E-700 operates

The E-700 provides efficient image processing and printing control. The E-700 board includes a 366MHz Intel Celeron CPU that runs the PostScript Interpreter. It interprets a page description file to produce the image pattern in memory. The RipChips™ on the board control data management and other system functions, freeing up the CPU for efficient image data processing.

Two high-speed DIMMs (dual in-line memory modules) on the E-700 board hold image data during printing. The standard memory configuration is 256MB.

With Fiery Scan software, the E-700 acquires RGB (red, green, blue) image data from the copier, stores it in memory, and transmits it to the computer that requested the scan.

The PCI-based video interface board provides communication with the color engine. Image data is sent via the video interface connector on the video interface board that attaches to both the E-700 board and the copier I/F unit. Raster data is supplied to the laser in the copier at full copier rated speeds.

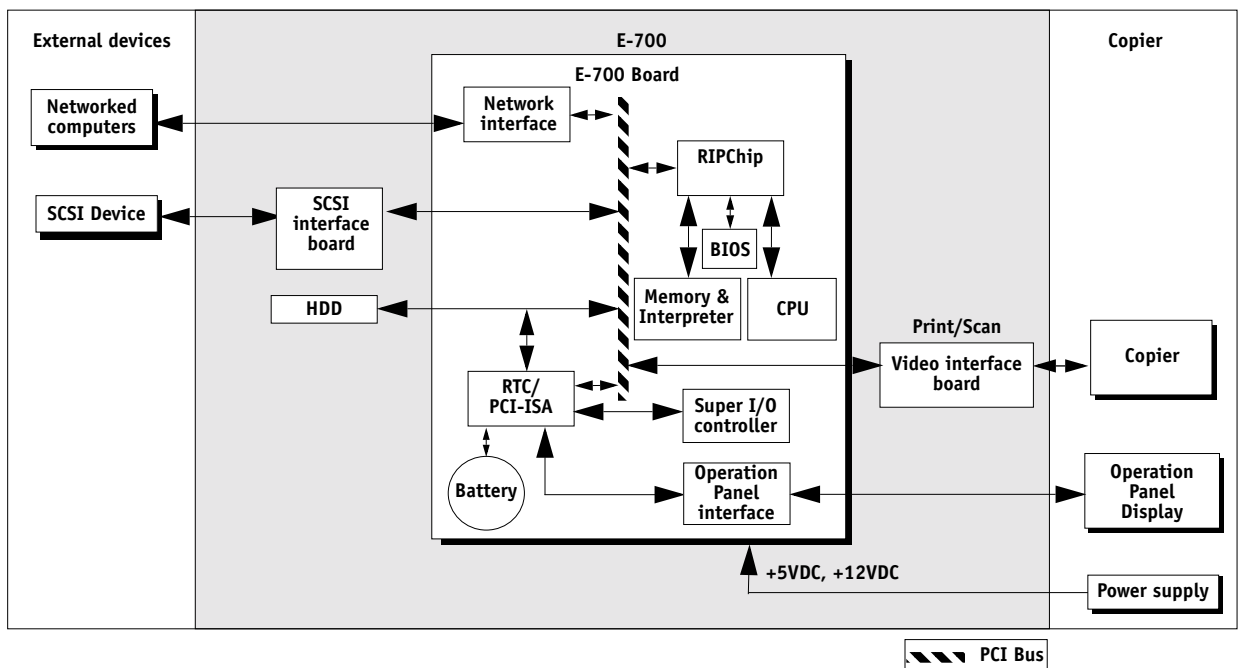

FIGURE 1-2 E-700 functional diagram

1 E-700 print options

E-700 print options

The E-700's efficient PostScript capabilities allow customers to use a variety of applications to create printed color or black and white pages of text and/or images. The E-700 operates over a network. Since the E-700 has the ability to print an image while processing the next image (RIP-While-Print™), it is capable of printing documents at full copier speeds.

Users can print documents directly from the applications in which they were created. In addition, the E-700 offers an efficient way to print files that have been saved in PostScript, EPS (Encapsulated PostScript), or PDF format. These files can be downloaded directly to the E-700 using the Fiery Downloader, a remote utility provided with E-700.

User software

User software is provided on the User Software CD. The network administrator or the user at the customer site is responsible for installing software onto computers that will use the E-700 over the network. See *Getting Started* for details.

The User Software CD includes:

Adobe PS Printer Driver	Enables users to print to the E-700 from Windows 95/98, Windows NT 4.0, and Mac OS computers; also supports special E-700 and PostScript 3 features. NOTE: Windows 2000 users should use the Microsoft PostScript Printer Driver provided with Windows 2000.
PostScript Printer Description file (PPD)	For use with the PostScript printer driver that allows the E-700 to appear in popular applications' Print and Page Setup dialog boxes. The E-700 PPDs provide information about the E-700 and the user's particular copier model to the application and printer driver in use.
PostScript Fonts (Mac OS only)	PostScript screen and printer fonts that correspond to the 136 PostScript printer fonts installed on the E-700 (126 Adobe Type 1 and 10 TrueType). See the <i>Printing Guide</i> for a complete list of PostScript fonts installed on the E-700.
Fiery Downloader	Enables users to print PostScript files, Encapsulated PostScript (EPS) files, and Portable Document Format (PDF) files directly to the E-700 without opening the application in which they were created. Fiery Downloader also enables users to manage the printer fonts installed on the E-700.

1 Introduction

ColorWise Pro Tools	ICC-open color management and calibration tools; enables users to edit and download ICC profiles.
Fiery Scan	Plug-in modules for Photoshop that enable users to scan images from the copier directly into the application.
Fiery Link	Enables users to monitor the status of connected servers and the print jobs sent to them.
Command WorkStation software (available as an option on a separate CD)	Enables the operator to control E-700 functions from Windows workstations. For information on Command WorkStation software, see the <i>Job Management Guide</i> .
Color management files	ColorSync and ICM color management files that enables users to maintain consistent color from the original artwork to the colors displayed on the monitor to the printed output.
Color reference files	Reference pages that users can print to view the range of colors available on the E-700. For the most predictable color results, refer to these pages when defining colors in applications. For more information on color management, see the <i>Color Guide</i> .
Calibration files	Includes measurements files and targets to use with ColorWise Pro Tools. These files can be used to calibrate the E-700 if the users don't have a densitometer.
MRJ (Mac OS only)	Mac OS Runtime for Java installer v 2.1.4. MRJ is required by all Java-based Fiery utilities. When installing these utilities, if MRJ is not detected the MRJ installer is automatically launched.

Fiery WebTools

The E-700 can support Internet or intranet access with Fiery WebTools, which include Status, WebSpooler, WebLink, Installer, WebDownloader, and WebSetup. For more information on WebTools, see the *Configuration Guide* and *Getting Started*.

2

Setting customer expectations

Chapter 2: Installation

This chapter describes the process for installing the E-700 kit in the I/F unit. Topics include setting customer expectations, unpacking the E-700, and performing the installation.

Setting customer expectations

The customer should be informed of the following:

- Some nodes on the network may be unavailable during the installation.
- The network administrator needs to be available during the installation for network connectivity.

Equipment downtime and impact on the network can be minimized if the network administrator installs a network connector for the E-700 and confirms network functionality with the connector in place before the date scheduled for the installation.

- The network administrator should have a networked computer available during the installation. The appropriate software should already be installed. Documentation for the networked computer and the network operating software should be available.
- The network administrator should install the user software shipped with the E-700 (a package of user documentation is also included) onto networked Mac OS computers and PCs that will print to the E-700.

NOTE: This guide covers E-700 hardware installation and service. It provides general information on connecting the E-700 to the customer's network. Network setup and configuration information go beyond the scope of this guide. For network setup and configuration information, the network administrator should refer to the *Configuration Guide*.

2 Installation

Unpacking the E-700

NOTE: The E-700 is assembled and shipped from the factory in a box that includes items shown in Figure 2-1. The E-700 requires the Controller Interface Type F kit to be installed. See the installation procedure in Appendix B, “Controller Interface Type F.”

TO UNPACK THE E-700

1. **Open the shipping box and remove any packing materials.**
2. **Remove the contents of the shipping box and inspect them for visible damage.**

If you notice shipping damage, have the shipping box ready to show the carrier if necessary. Call the carrier immediately to report the damage and file a claim, then call your authorized service/support center. The shipping box includes the following items:

- E-700
- Media package that contains the following:
 - User Software CD (see page 1-3 for contents) and Peripheral Manager CD
 - User documentation (which includes *Getting Started*, the *Printing Guide*, the *Job Management Guide*, the *Color Guide*, the *Configuration Guide*, and Release Notes)
 - Kodak Color Separation and Gray Scale (small)

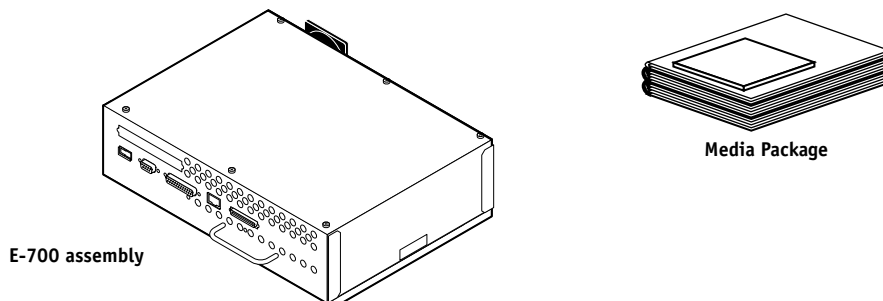

FIGURE 2-1 Contents of shipping box

3. **Give the media package to the network administrator.**

Let the network administrator know that in order to take full advantage of the E-700, the user software must be installed on computers that will print to it.
4. **Give the Kodak Color Separation and Gray Scale (small) to a person at the customer site who is responsible for calibration.**
5. **Remove any protectors that may be installed on connectors on the E-700.**

If a jack is installed in the E-700 RJ-45 connector, grasp the jack with needlenose pliers and pull it straight out of the connector.

2

Preparing for installation

Preparing for installation

Before installing the E-700, do the following:

Test copier functionality.

Copy the copier test page before you install the E-700.

If the copied image indicates that the copier needs adjustment, inform the customer. After getting approval, complete the copier service needed.

Check the network.

Verify that the network is functioning before you attach the E-700.

- Ask the network administrator to print a document on a shared printer over the network.
- Ask the network administrator to verify the computer and network requirements as specified in *Getting Started*, one of the documents provided in the Media Package.

Install the Controller Interface Type F kit.

See the installation procedure in Appendix B, “Controller Interface Type F.”

Opening the copier

To gain access to the location inside the copier where the E-700 will be installed, you need to shut down the copier and open the copier from the back.



Follow standard ESD (electrostatic discharge) precautions while handling components.

TO SHUT DOWN THE COPIER

1. **Make sure the copier is not in use.**
2. **At the Control Panel Idle screen, Press the Menu button to access the Functions menu.**
3. **Use the Down arrow to scroll to Shut Down. Press the Enter button.**
4. **Use the Down arrow to scroll to Shut Down System. Press the Enter button.**
5. **Power off the copier using the main power switch on the side.**
6. **Disconnect the copier power cable from the wall outlet and any external cables.**

2 Installation

TO OPEN THE COPIER

1. Shut down the copier (see page 2-3).
2. Remove the I/F unit cover from the back of the copier (4 screws).
Set aside the I/F unit cover and screws so you can replace them later.

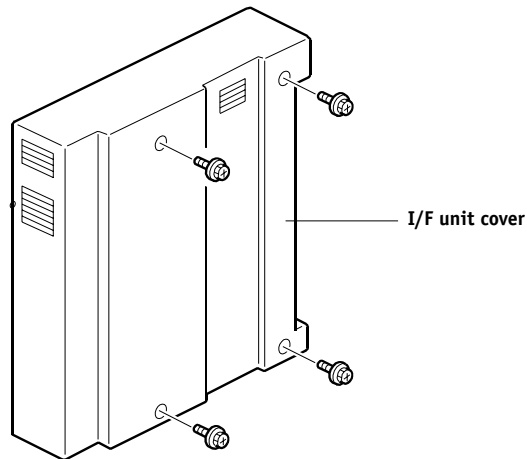

FIGURE 2-2 Removing the I/F unit cover

3. Remove and set aside the 2 screws that attach the E-700 to the I/F unit.

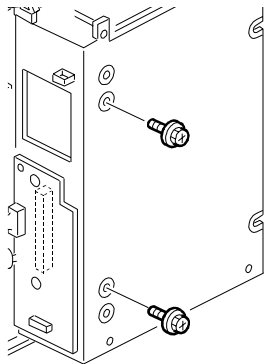

FIGURE 2-3 I/F unit screws

4. Remove the upper shield cover (2 screws) then the right shield cover (6 screws).
Set aside the covers and screws so you can replace them later. For more information and illustrations, see Appendix B, "Controller Interface Type F."

The area for the E-700 is now accessible. Make sure the entire Controller Interface Type F kit is installed before attempting to install the E-700. See Appendix B, "Controller Interface Type F."

2

Opening the copier

Installing the E-700 in the copier

TO INSTALL THE E-700

1. **Observe the top and bottom slide guides inside the I/F unit and on the outside of the E-700.**

Make sure the slide guides inside the I/F unit have approximately a 30 degree lead-in angle. If necessary, bend them to create the proper angle (see Figure 2-4 on page 2-5).

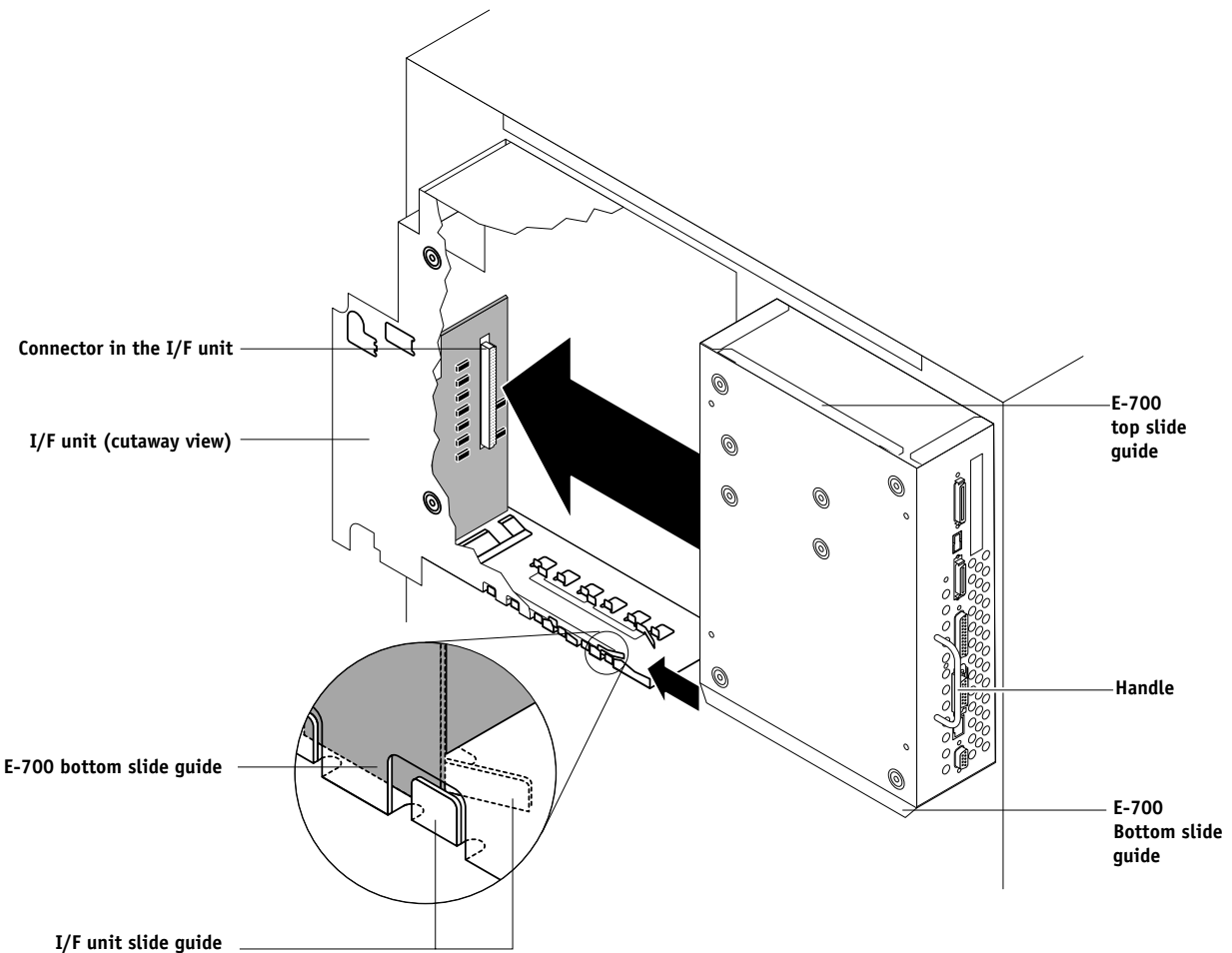

FIGURE 2-4 Installing the E-700 in the I/F unit

2. **Hold the E-700 by the handle and slide it into the I/F unit, using the slide guides on the E-700 and inside the I/F unit to align the E-700.**



Make sure the E-700 is aligned inside both the top and bottom slide guides. If misaligned, the copier interface connector on the video interface board can be damaged.

2 Installation

3. Push the E-700 until the connector in the I/F unit and the copier interface connector on the video interface board are securely connected.

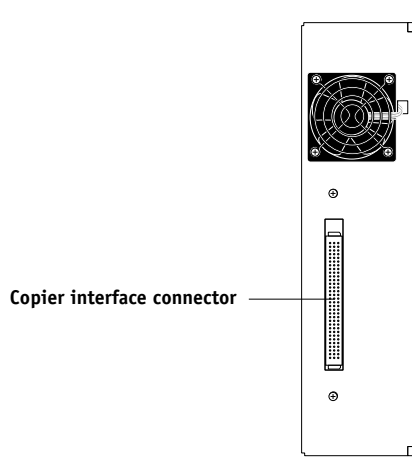

FIGURE 2-5 Copier interface connector

4. Reassemble the copier as described in the following section.

Reassembling the copier

It is recommended that you fully reassemble the copier before you apply power to verify E-700 functionality.

TO REASSEMBLE THE COPIER

1. **Attach the E-700 to the I/F unit with the 2 screws you removed earlier.**
For the screw locations, see Figure 2-3 on page 2-4.
2. **Replace the right cover shield (6 screws) then the upper shield cover (2 screws) that you removed earlier.**
For more information and illustrations, see Appendix B, "Controller Interface Type F."
3. **Replace the I/F unit cover (4 screws).**
See Figure 2-2 on page 2-4.
4. **Connect the main power cable to the wall outlet and to the copier.**

2 Reassembling the copier

Initial startup

Once the E-700 is installed in the copier, you are ready to start the unit up.

To STARTUP THE E-700

1. **Power on the copier.**
2. **If the Select Language screen is displayed, display the language of your choice, press the Enter key, then wait for the Setup screen to be displayed.**

The first time the copier is powered on following installation of Controller Interface Type F components and the E-700 (or following the reinstallation of system software), you are prompted to select the language to be used for both the E-700 Operation Panel and special E-700 pages, such as the Configuration page. Use the up and down arrows to cycle through the languages available.

If you select a different language, the prompt to reboot appears in the language you selected. Press the Enter key to reboot then wait for the Setup screen to be displayed. To change the language again, you must reinstall system software.

3. **If the Setup screen is displayed, select Server, Printer, Network, and Exit Setup.**

Before you can exit Setup, you must first enter Server Setup, Network Setup, and Printer Setup and save changes. Enter each Setup, press the Cancel key, and when prompted to save changes, select Yes.

It is the network administrator's responsibility to configure Setup according to the network and user environment. At this stage, default settings in Setup are adequate although they may not be optimal for the user's environment. Refer the network administrator to the *Configuration Guide* for Setup information.

4. **Allow the system to proceed to the Info screen to confirm that the E-700 is operating normally. Scroll down to display E-700 status.**

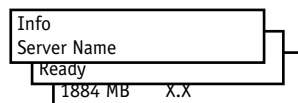

Once the E-700 reaches the Info screen, you are ready to print a Test Page and then connect the E-700 to the network (see "Printing a Test Page" on page 2-8).

2 Installation

Printing a Test Page

Before connecting the E-700 to the network, print a Test Page to verify that the E-700 is embedded properly in the copier and working. The Test Page is a file that resides on the E-700 hard disk drive.

TO PRINT A TEST PAGE

1. If the copier is powered off, power it on.
2. Wait while the E-700 and the copier perform their startup sequences.

The E-700 displays the Info screen when ready. The copier beeps when ready. Scroll down to display E-700 status.

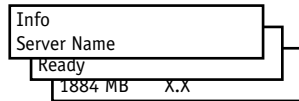

3. Press the Menu key to access the Functions screen.
4. Select Print Pages.

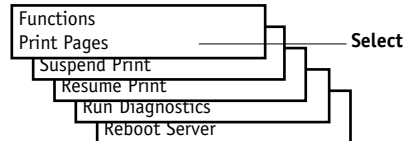

5. Select Test Page.
6. Examine the Test Page.

Success in printing the Test Page confirms that the E-700 is functional and connected properly to the copier. Poor quality may indicate a need to service or adjust the copier, not the E-700.

2 Printing the Configuration page

Printing the Configuration page

The Configuration page can be helpful during installation, setup, and service. After installation of the E-700 and before any default settings are changed, you can obtain a record of the defaults by printing the Configuration page.

After the physical connection to the network is made, the network administrator can customize Setup options according to the network and user environment. Using the Configuration page as a guide can help speed up this process. For more information, see the *Configuration Guide*.

Before you perform any service procedure, you should print the E-700 Configuration page, if possible, so that you are prepared to return the settings to their former configuration, if necessary.

TO PRINT THE CONFIGURATION PAGE

1. If the copier is powered off, power it on.
2. Wait while the E-700 and the copier perform their startup sequences.

The E-700 displays the Info screen when ready. The copier beeps when ready. Scroll down to display E-700 status.

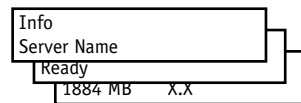

3. Press the Menu key to access the Functions screen.
4. Select Print Pages.

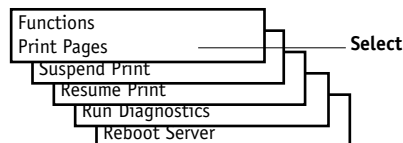

5. Select Configuration.
6. Save the Configuration page for future reference.

2 Installation

Connecting the E-700 to the network

The E-700 board provides connectivity to an Ethernet network, either thinnet, thicknet, or twisted pair.

Ethernet network connection

The E-700 board has an external Ethernet 10BaseT/100BaseT RJ-45 connector for attaching a Category 3 or Category 5 unshielded twisted pair (UTP) network cable (see Figure 2-6). Category 5 is required for 100BaseT.

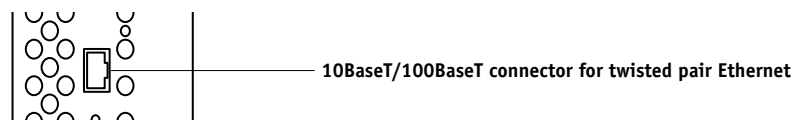

FIGURE 2-6 E-700 network connectors

TO CONNECT A TWISTED PAIR CABLE TO THE E-700

A Category 5 unshielded twisted pair (UTP) network cable must be used for 100BaseT. It connects to the RJ-45 connector on the E-700.

1. **Power off the E-700 before connecting the E-700 to any network device.**
2. **Connect the network cable to the RJ-45 connector on the E-700.**
3. **Configure Setup options.**

It is the network administrator's responsibility to configure Setup according to the network and user environment. Default settings in Setup are adequate although they may not be optimal for the user's environment. Refer the network administrator to the *Configuration Guide* for Setup information.

4. **After configuring Setup options, verify the network connection.**

Once the network connection has been made and the E-700 has the correct Setup configuration and is Ready, the E-700 should be available on the network.

The network administrator should perform any additional network Setup, verify the network connection, verify that the E-700 appears in the list of printers, and print a few test documents from a networked computer that will use the E-700.

See the *Configuration Guide* for more information.

3 Overview

Chapter 3: Using the E-700 Operation Panel

This section describes the functions on the E-700 Operation Panel. The E-700 Operation Panel is an area dedicated to E-700 functions. It is located on the top left side of the copier Operation Panel. The keys on the E-700 Operation Panel allow you to access and monitor different features of the E-700. This guide does not attempt to describe all functions of the Operation Panel, only those functions that pertain to the E-700. For information on installing the E-700 Operation Panel, see the installation procedure in Appendix B, “Controller Interface Type F.”

Overview

Current status and Setup information are displayed on the E-700 Operation Panel. Print activity can be monitored in the display window and specific E-700 functions (such as printing a Test Page) are controlled using the keys on the E-700 Operation Panel. Three LEDs assist in providing status information.

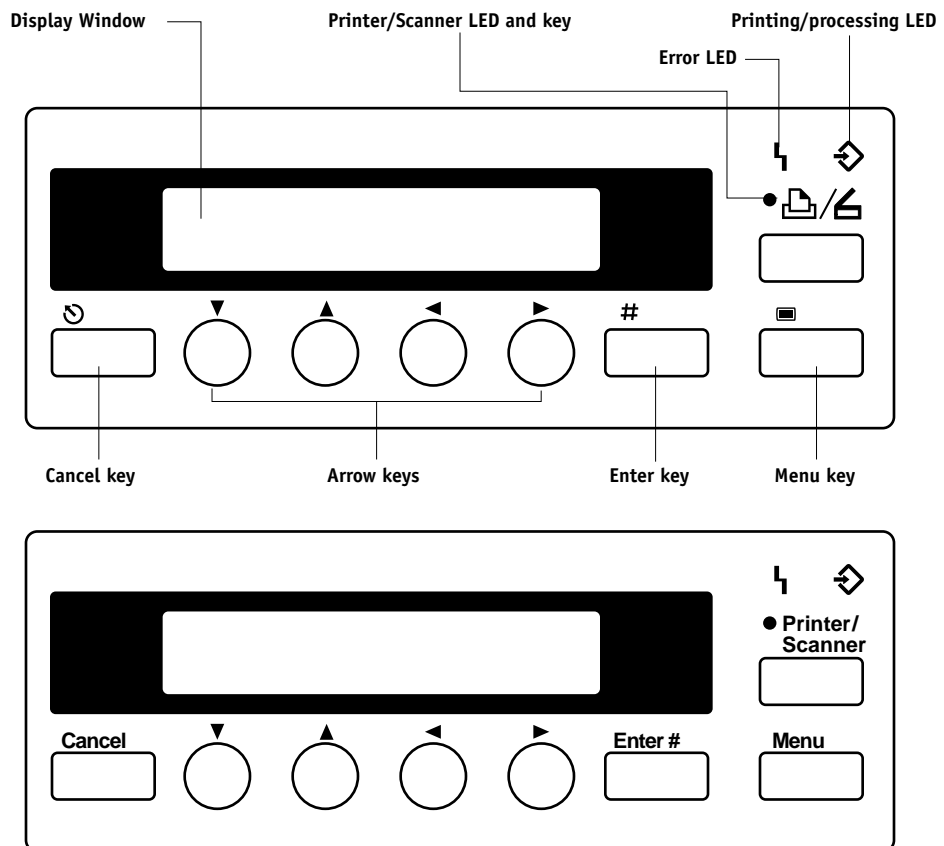









FIGURE 3-1 E-700 Operation Panel (International and U.S. models)

3

Using the E-700 Operation Panel





Keys

Once the E-700 board is installed in the copier, use the E-700 keys on the Operation Panel to perform the following functions:

Key (International)	Key (U.S.)	Description
	Menu	From the Info screen, display the Functions screen when idle and the run-time screen when a job is in process.
	Enter #	Select the currently displayed menu item and proceed to the next screen. Cancel a job from the printing or processing screen.
	▼	Scroll down the screen to display menu items or part of a text message. After the bottom of the screen is reached, the top of the screen is displayed.
	▲	Scroll up the screen to display the previous menu item or part of a text message. When the top of the screen is reached, the bottom of the screen is displayed.
	▲	Backspace the cursor to the text-entry position to the left. In a text field, it deletes the character to the left.
	▶	Advance the cursor to the text-entry position to the right.
	Cancel	In the menus, return to previous level.
	Printer/Scanner	Switch from copier mode to Printer/Scanner mode. See the Copier service manual for information.

Activity indicators

Once the E-700 board is installed in the copier, the red and green activity lights on the E-700 Operation Panel turn on and stay solid or flash on and off to indicate the following:

Activity indicator (International)	Activity indicator (U.S.)	Description
		<ul style="list-style-type: none">Flashing red—An error prevents the E-700 from processing a job (see the <i>Printing Guide</i> for more information).Solid red (more than 30 seconds)—A communication error has occurred between the E-700 and the copier.
		<ul style="list-style-type: none">Flashing green—The E-700 is processing a job or communicating with a remote computer.
	Printer/Scanner	<ul style="list-style-type: none">Solid green—The E-700 is using the copier to print or scan a job.

3 Screens

Screens

When the copier is idle, E-700 status information and functions available from the E-700 Operation Panel. You can monitor print activity, control E-700 functions, and access the E-700 Setup menus.

When a job is sent to the copier, the E-700 Operation Panel cycles through the RIP and Print screens, and then displays the Info screen. If an error occurs, the Alert screen is displayed with a message describing the error. A Startup screen is also available. It is made available when the system is powered on or when you reboot the system. It has options for setting up the printer, rebooting the E-700, and installing system software.

These screens contain the following information:

Info status screen

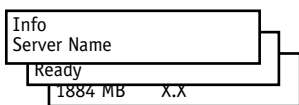

The first line of this screen displays the printer's name on the network. Scrolling down displays the status of the E-700, the amount of disk space available on the hard disk drive, and the current system software version. Normally, if no jobs are currently being processed or printed, the Info screen displays Ready (a job may be between processing and printing). The Info screen is the default screen. Press the Menu key to display the Functions screen.

RIP status screen

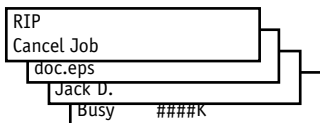

Appears when a job is being processed. Displays the name of the file, the name of the user who sent the job, the status, and the amount of the job in kilobytes that has been processed so far. To cancel the job, display Cancel Job and press the Enter key. Press the Cancel key to display the Functions screen.

Print status screen

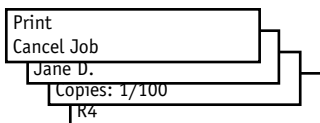

Appears when a job is being printed. Displays the name of the user who sent the job, the number of copies printed so far, and the number of copies requested. To cancel the job, display Cancel Job and press the Enter key. Press the Cancel key to display the Functions screen.

Alert screen

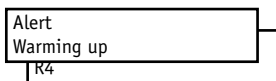

Displays a message if an error or other Alert condition arises. Pressing the down arrow key may be necessary to view the entire error message. If other screens are being accessed, the Alert screen is redisplayed frequently until the condition is resolved. Press the Cancel key to display the Functions screen.

Functions screen

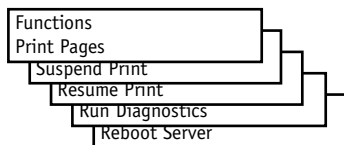

Gives you access to administrative functions not normally performed from a remote workstation (see "Functions screen" below for information on the available functions). Press the Cancel key to display the Info screen.

3

Using the E-700 Operation Panel

Functions screen

The Functions screen allows you to perform a variety of administrative functions that do not affect print jobs of other users. Use the up and down arrow keys to scroll through the menu items. Press the Enter key to select the menu item displayed. Press the Cancel key or do nothing to return to the Info screen. The following options are available from the Functions screen:

Print Pages—Enables you to print special pages from the copier:

- **Test Page**—Prints the Test Page resident on the E-700 hard disk drive. The Test Page confirms that the E-700 is properly installed in the copier and allows you to view information about color and grayscale to troubleshoot E-700 functions. Test Page information includes but may not be limited to: Server name, Printer name, Calibration, Measurements, Target, Date & Time, CMYK Simulation, RGB Source, Rendering Style, Color Mode. For more information see the *Printing Guide* and the *Configuration Guide*.
- **Configuration**—Prints the current device configuration, including information about all current Setup settings, calibration profile, and the Ethernet address of the E-700 board.
- **Job Log**—Prints the log of the last 55 jobs. For more information about the job log, see the *Printing Guide*.
- **Menu Map**—Prints the E-700 Menu Map, useful when navigating through the different E-700 Setup screens.
- **Color Charts**—Prints the color reference charts, including swatches of the RGB, CMY, and Pantone colors available from the E-700.
- **Font List**—Prints a list of all the fonts resident on the E-700 hard disk drive.

Suspend Printing— This option interrupts the current print job so you can use the copier to make copies. If it has not finished processing, the RIP will continue but the job will not print. You can then select **Resume Printing**.

Resume Printing—Resumes printing after interrupting the print job in order to make copies.

Run Diagnostics—Select this option to access:

- **Video Diagnostics**— Runs diagnostics on the E-700 video interface (see “Video board diagnostics” on page 5-7).

Reboot Server—Shuts down all printing activity properly and then restarts the E-700. Access to E-700 Setup options are made available at this time.

3 Screens

Startup screen

- The Startup screen is made available when you reboot the system from the Functions screen or when you power on the copier. The following options are available from the Startup screen.

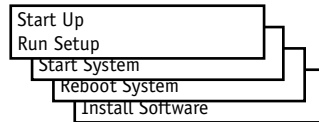

- Run Setup—allows you to access E-700 Setup options in order to configure the network and printing environment. Typically it is the network administrator's responsibility to configure Setup according to the network and user environment. Setup is required the first time the copier is powered on after new E-700 system software is installed. You must enter and save changes to Server, Network, and Printer Setup after installing system software.

Setup options include: Server, Network, Printer, PS Setup, Color Setup, Job Log Setup, Calibration, Change Password, and Clear Server. See the *Configuration Guide* for detailed information on Setup.

NOTE: Make sure the network administrator is available to customize Setup options according to the network and user environment.

- Start System—Exits the Start Up screen and displays the Info screen.
- Reboot System—Shuts down all E-700 activity in the correct manner and restarts the E-700. Press the Enter key to reboot the E-700. Once the server reboots you can access Setup options.

4

Overview

Chapter 4: Service Procedures

Generally, the Color Controller E-700 does not require regular maintenance. Use the procedures in this chapter to inspect, remove, reseal, or replace major hardware components and also to install system software.

Overview

This chapter includes information on the following:

- Cable connections (page 4-5)
- E-700 board (page 4-8)
- E-700 board components
 - Video interface board (page 4-12)
 - SCSI interface board (page 4-14)
 - DIMMs (page 4-15)
 - Battery (page 4-16)
 - CPU fan (page 4-17)
- Exhaust fan (page 4-18)
- Hard disk drive (page 4-19)
- System software (page 4-24)

For information on how to remove and replace the I/F unit that encloses the E-700, see the installation procedure in Appendix B, “Controller Interface Type E”.

See Figure 4-1 on page 4-2 for an overview of E-700 board components. Replacement parts are available from your authorized service representative.



When performing the procedures described in this chapter, see “Precautions” on page xiii and “Tools you will need” on page xiv.

The E-700 system software is installed on the hard disk drive at the factory. You will need to re-install system software if you:

- Replace the hard disk drive
- Upgrade to a more recent version of the system software

4 Service Procedures

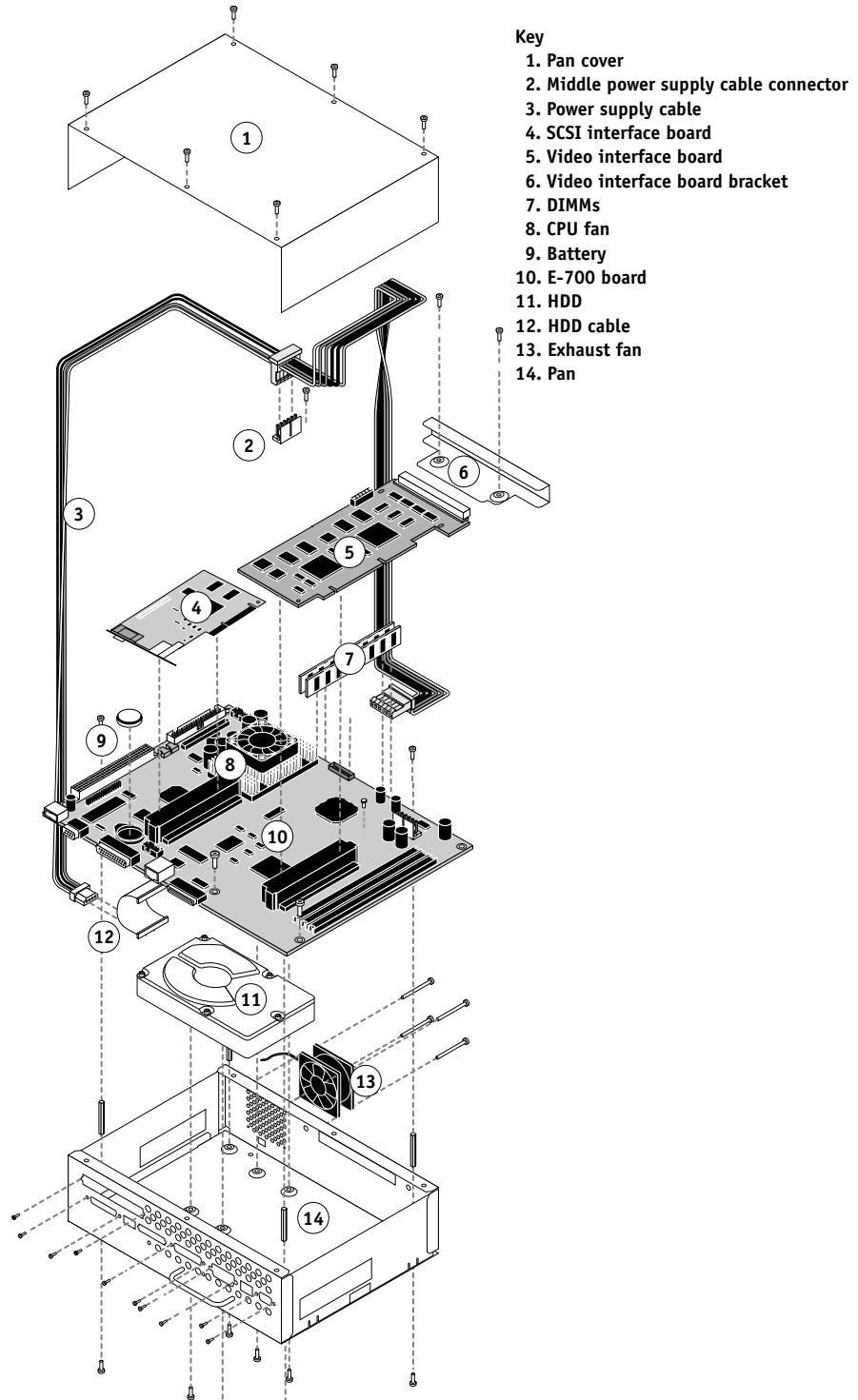

FIGURE 4-1 Exploded view of E-700

4 Accessing the E-700

Accessing the E-700



Always use the following procedures when accessing the E-700. Make sure you attach an ESD grounding wrist strap and follow standard ESD (electrostatic discharge) precautions before following this procedure.

TO SHUT DOWN THE COPIER

1. Make sure the copier is not in use.
2. At the Control Panel Idle screen, Press the Menu button to access the Functions menu.
3. Use the Down arrow to scroll to Shut Down. Press the Enter button.
4. Use the Down arrow to scroll to Shut Down System. Press the Enter button.
5. Power off the copier using the main power switch on the side.
6. Disconnect the copier power cable from the wall outlet and any external cables.

TO ACCESS THE E-700

1. Shut down the copier as described above.
2. Remove the I/F unit cover from the back of the copier (4 screws).
Set aside the I/F unit cover and screws so you can replace them later.

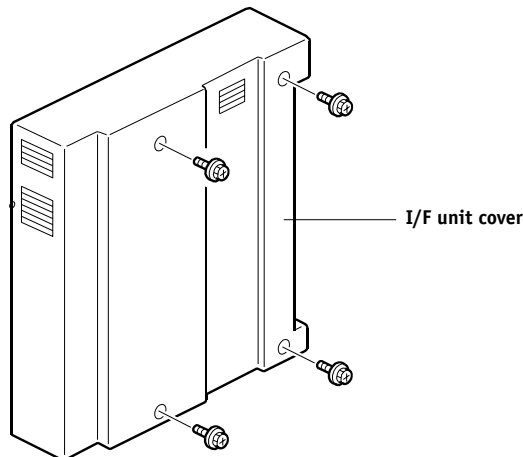

FIGURE 4-2 Removing the I/F unit cover

3. Remove the upper shield cover (2 screws) then the right shield cover (6 screws).
Set aside the covers and screws so you can replace them later. For more information and illustrations, see Appendix B, “Controller Interface Type F.”

4 Service Procedures

4. Remove the 2 screws that attach the E-700 to the I/F unit.

Set aside the screws so you can replace them later.

5. Use the handle to pull out the E-700 from the I/F unit.

Set the E-700 on a stable static-free surface.

6. Remove the six screws that secure the pan cover. Lift off the pan cover and set it aside.

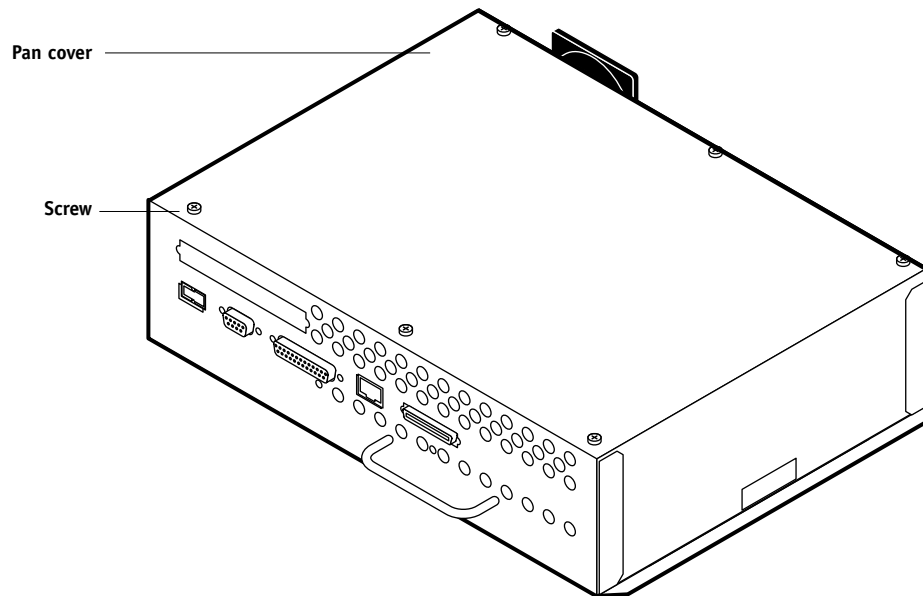

FIGURE 4-3 Removing the pan cover

The E-700 components are now accessible.

4

Checking E-700 internal connections

Checking E-700 internal connections

The most common causes of hardware problems are faulty and loose connections. Before you conclude that any board or component has failed, remove, inspect, and reseal all appropriate connections, and then verify that the problem still occurs.

TO CHECK BOARD AND CABLE CONNECTIONS



- 1. Before you touch any parts inside the E-700, attach a grounding wrist strap. Touching the pan also discharges static electricity.**
- 2. Place the E-700 so the internal components of the E-700 are facing up.**
- 3. Make sure the DIMMs are properly installed (see “To replace a DIMM” on page 4-15 for the proper procedure).**
- 4. Make sure the battery is properly installed (see “To replace the battery” on page 4-16).**
- 5. Make sure the video interface board is properly installed (see “To replace the video interface board” on page 4-13).**
- 6. Inspect the copier interface connector on the video interface board.**
If any pins are pushed in or bent, gently fix them with a pair of small needlenose pliers.
- 7. Make sure the SCSI interface board is properly installed (see “To replace the SCSI interface board” on page 4-14)**
- 8. Inspect the HDD cable to make sure it is intact.**
Faulty ribbon cables are easily overlooked. Check the contact point between the cable and the connector to ensure that they have not separated. If a ribbon cable is suspect, substitute it with a tested cable.
- 9. Check the fan cables of the exhaust fan and the CPU fan.**
Make sure the cables are intact. Also, check airflow direction. When the fans are installed properly:
 - An arrow on the exhaust fan points away from the E-700
 - An arrow on the CPU fan points to the CPU
- 10. Make sure the power cable is intact and properly connected to the HDD, video interface board, and E-700 board.**

The power cable has 3 connectors. For the best fit inside the chassis, the middle connector is attached to the video interface board and the 6-wire end connector is attached to the E-700 board. The 4-wire end connector (to the HDD) is keyed, however, the connectors to the video interface board and the E-700 board are not keyed.

4 Service Procedures



Make sure the connectors to the video interface board and the E-700 board are installed so that the lip of the connector fits under the ridge of the board connector. If oriented backwards, the boards can be damaged. See the figures below.

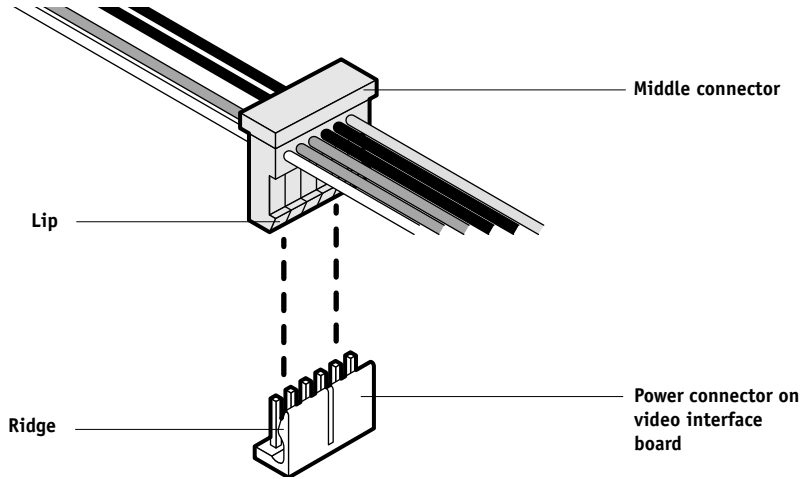

FIGURE 4-4 Power cable middle connection

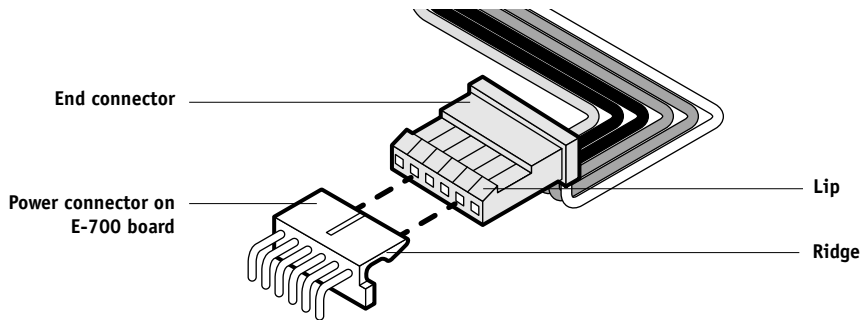

FIGURE 4-5 Power cable end connection

4

Replacing parts of the E-700

Replacing parts of the E-700

The E-700 board has a 366MHz Intel Celeron CPU. The E-700 board provides the Ethernet networking interface, controls hard disk drive functions, and handles the communication between the E-700 and external devices. With its video interface board it controls the video image data transferred to and from the copier.

When replacing any of its components, make sure to protect the E-700 board from excessive bending and flexing. When possible, remove the E-700 board from the pan and remove the standoffs from the board's corners and lay the E-700 board flat before servicing.

Following are instructions for accessing, removing, and replacing the following parts of the E-700:

- E-700 board
- E-700 board components including
 - Video interface board
 - SCSI interface board
 - DIMMs
 - Battery
 - CPU fan
- Exhaust fan attached to the pan
- HDD



Make sure you attach an ESD grounding wrist strap and follow standard ESD (electrostatic discharge) precautions before following this procedure.

4 Service Procedures

E-700 board

The E-700 board is installed in the pan on four standoffs. This section includes instructions for replacing the E-700 board and E-700 board components.

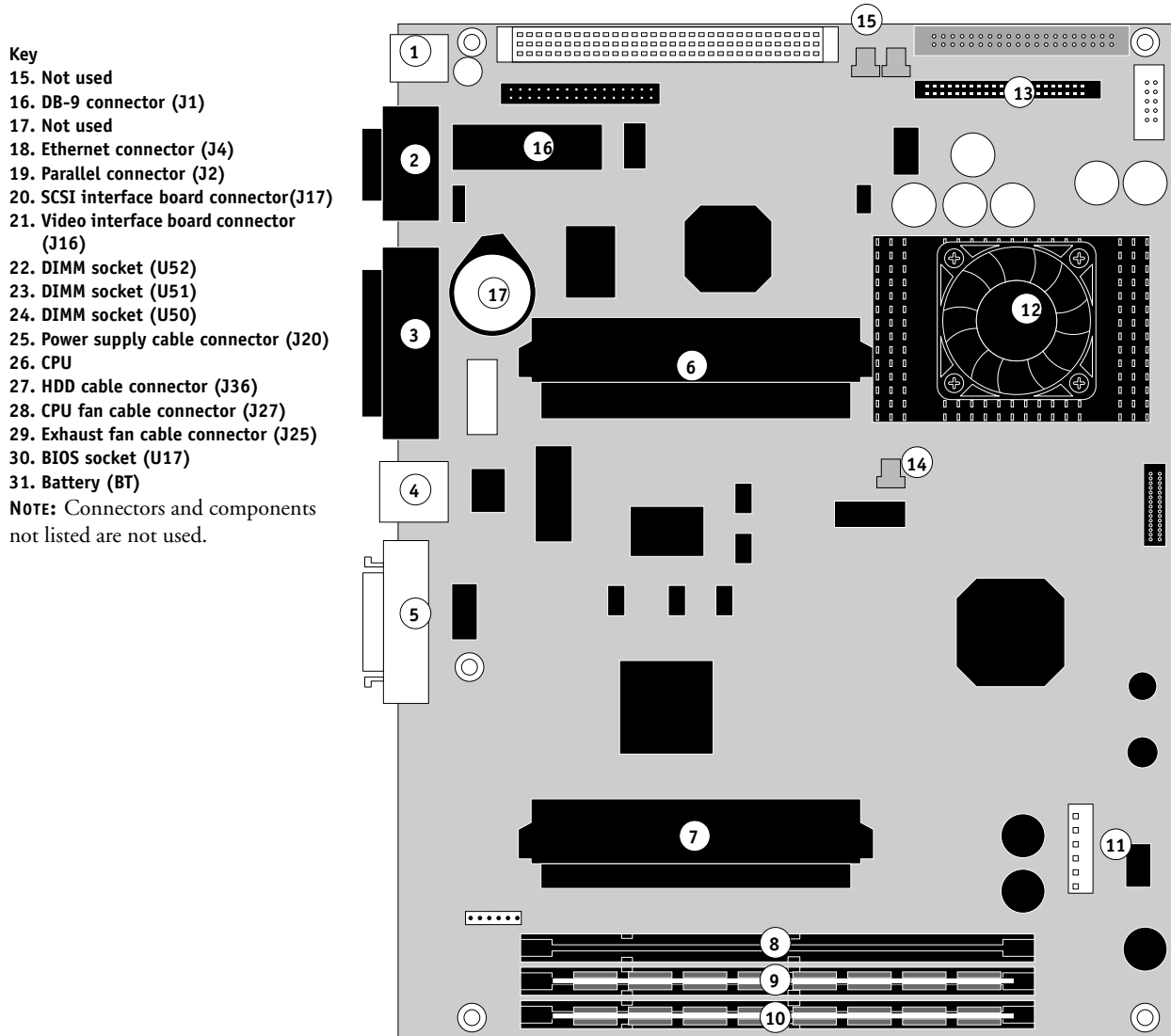

FIGURE 4-6 E-700 board layout

4 Replacing parts of the E-700

TO REMOVE THE E-700 BOARD

1. Shut down the copier and access the E-700 as described on page 4-3.
2. Remove the video interface board from E-700 board connector J17 (see page 4-12).
3. Remove the SCSI interface board from board connector J16 (see page 4-14)
4. Remove the connector bracket from the pan (see Figure 4-1 on page 4-2). Set the two screws and the connector bracket aside so you can replace them later.
5. Remove the support bracket from the pan (see Figure 4-1 on page 4-2). Set the two screws and the support bracket aside so you can replace them later.
6. Remove the exhaust fan cable from E-700 board connector J25 (see "Exhaust fan" on page 4-18).
7. Remove the HDD cable from E-700 board connector J36.
Using a ribbon cable connector extractor is recommended.
8. Remove the screws on the face plate that secure the board connectors to the face plate as shown below.

Make sure to keep each set of screws together.

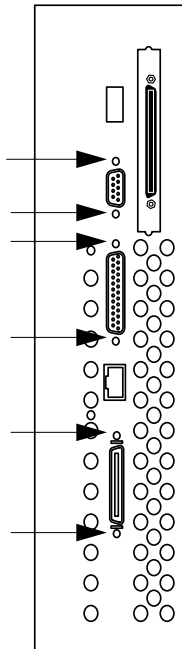

NOTE: Use a #1 Phillips screwdriver for the SCSI connector and the parallel connector.

NOTE: Use a 3/16" hex nut driver to remove the standoffs on the 9-pin D connector and the 25-pin D connector.

FIGURE 4-7 External E-700 connectors

4

Service Procedures

9. **Remove and set aside the four screws that secure the E-700 board to the standoffs.**
10. **Remove the power cable from E-700 board connector J16.**

Lift the E-700 board off the standoffs and carefully tilt it out of the pan to access the power cable.
11. **Completely remove the E-700 board from the pan. Place the board on a stable antistatic work surface or into an antistatic bag.**

Tilt the board as necessary to make sure the connectors clear the pan as you remove the board.

TO REPLACE THE E-700 BOARD

NOTE: To make sure the copier interface connector (on the video interface board) is properly aligned, make sure not to tighten screws until all components are in place.

1. **Place the E-700 board inside the pan so the external connectors fit into the pan cutouts.**
2. **Connect the end connector of the power cable to E-700 board connector J16.**

Make sure the HDD is already installed with both cables attached. From the HDD, route the power cable between the pan and the pan standoff. Carefully tilt the E-700 board to make the connection.



Improper connection of the power cable can damage the E-700. See “Checking E-700 internal connections” on page 4-5 including Figure 4-5 on page 4-6.

3. **Align the E-700 board with the pan standoffs and then replace the four mounting screws into the pan standoffs.**
4. **Insert the screws (and washers, if present), and standoffs that attach the external connectors to the pan (see Figure 4-7 on page 4-9).**

Use a 3/16" hex nut driver to install the standoffs on the 9-pin D connector and the 25-pin D connector. Use a #1 Phillips screwdriver for the SCSI connector and the parallel connector.

5. **Connect the HDD cable to E-700 board connector J36.**
6. **Connect the exhaust fan cable to E-700 board connector J25.**
7. **Attach the support bracket to the pan (see Figure 4-1 on page 4-2) using the two screws you removed earlier.**
8. **Attach the connector bracket to the pan (see Figure 4-1 on page 4-2) using the two screws you removed earlier.**

Make sure that the connector bracket is flat against the inside of the pan and the two mounting holes are aligned with the screw holes in the pan.

9. **Install the video interface board in E-700 board connector J17 (see page 4-12).**

4

Replacing parts of the E-700

10. Install the SCSI interface board in board connector J16 (see page 4-12)
11. Reassemble the copier and verify functionality as described in "Restoring E-700 functionality after service" on page 4-22.
12. If you replaced the E-700 board with a new one, install system software (see page 4-24). If a startup error occurs when you power on the copier, check E-700 connections. If a startup error still occurs, call your authorized service/support center.

4

Service Procedures

Video interface board

The video interface board provides the interface between the E-700 and the copier. It connects to video interface connector J17 on the E-700 board and to the connector in the I/F unit (see Figure 4-8 and Figure 2-4 on page 2-5).

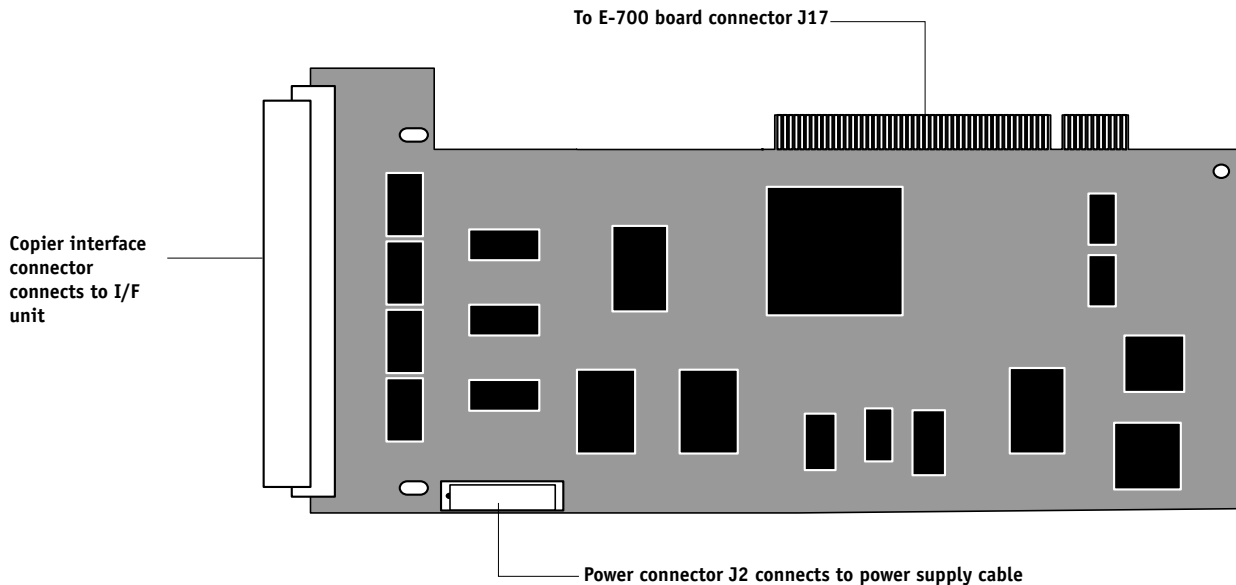

FIGURE 4-8 Video interface board layout

TO REMOVE THE VIDEO INTERFACE BOARD

1. Shut down the copier and access the E-700 as described on page 4-3.
2. Remove the power cable from video interface board connector J2.
3. Remove and set aside the one screw that attaches the video interface board to the support bracket (for its location, see Figure 4-1 on page 4-2).
4. Remove and set aside the two screws that attach the video interface board to the connector bracket (for its location, see Figure 4-1 on page 4-2).
5. Gently remove the video interface board from E-700 board connector J17.
Grasp the board at the sides. Gently pull the board straight out of the connector.
6. Carefully tilt the video interface board out of the pan.
7. Place the board in an anti-static bag.

4

Replacing parts of the E-700

TO REPLACE THE VIDEO INTERFACE BOARD

NOTE: To make sure the copier interface connector is properly aligned, make sure not to tighten screws until all components of the E-700 are in place.

1. **Remove the board from the anti-static bag.**
2. **Carefully tilt the video interface board into the pan and insert the video interface board into E-700 board connector J17.**

Grasp the board at the sides. Gently push the board straight into the connector. Check the visible portion of the gold fingers of the connector on the video interface board to determine if the connection is aligned properly and secure.

3. **Align the mounting hole in the video interface board with the hole in the connector bracket and attach the video interface board to the connector bracket (see Figure 4-1 on page 4-2) using the two screws you removed earlier.**
4. **Align the mounting hole in the video interface board with the hole in the support bracket and attach the video interface board to the support bracket (see Figure 4-1 on page 4-2) using the one screw you removed earlier.**
5. **Connect the middle connector of the power cable to video interface board connector J2.**

To avoid bending and flexing the video interface board, firmly seat the cable connector by pressing from the bottom of the board as you press the cable connector into J2.



Improper connection of the power cable can damage the E-700. See “Checking E-700 internal connections” on page 4-5 including Figure 4-5 on page 4-6.

6. **Reassemble the copier and restore functionality as described on page 4-22.**

When you reassemble the E-700, you will tighten all screws completely.

4

Service Procedures

SCSI interface board

The SCSI interface board provides the interface between the E-700 and an external CD-ROM drive or other external SCSI device. It connects to video interface connector J16 on the E-700 board (see Figure 4-8 and Figure 2-4 on page 2-5).

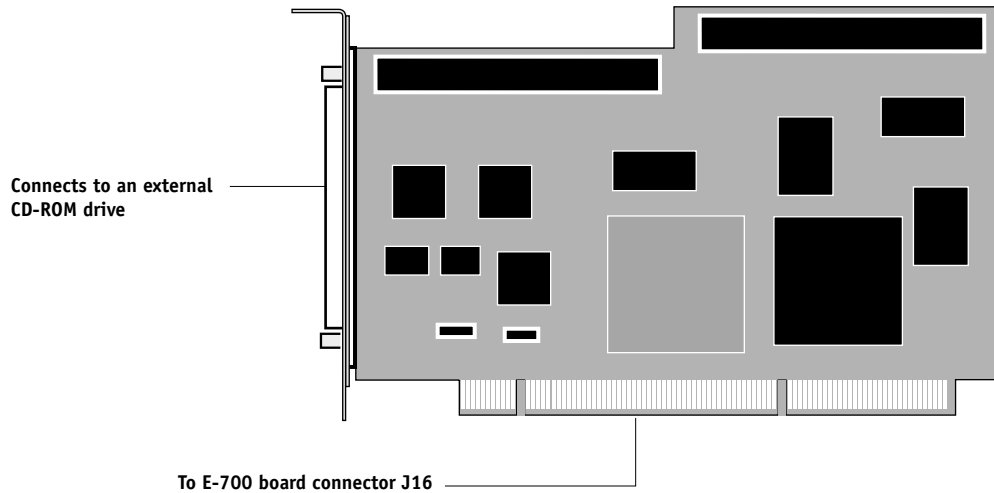

FIGURE 4-9 SCSI interface board layout

TO REMOVE THE SCSI INTERFACE BOARD

1. Shut down the copier and access the E-700 as described on page 4-3.
2. Gently remove the SCSI interface board from E-700 board connector J16.
Grasp the board at the sides. Gently pull the board straight out of the connector.
3. Carefully lift the SCSI interface board out of the pan.
4. Place the board in an anti-static bag.

TO REPLACE THE SCSI INTERFACE BOARD

1. Remove the board from the anti-static bag.
2. Insert the SCSI interface board into E-700 board connector J16.
Grasp the board at the sides. Gently push the board straight into the connector. Check the visible portion of the gold fingers of the connector on the video interface board to determine if the connection is aligned properly and secure.
3. Reassemble the copier and restore functionality as described on page 4-22.
When you reassemble the E-700, you will tighten all screws completely.

4

Replacing parts of the E-700

DIMMs

There are three DIMM sockets on the E-700 board: U52, U51, and U50. Each DIMM (dual in-line memory module) is held in place by levers at each end of its socket on the E-700 board.

NOTE: Approved DIMMs are available from your authorized service representative.

TO REPLACE A DIMM

1. To release a DIMM, push outward on the lever on each side of the DIMM.

See the following figure.

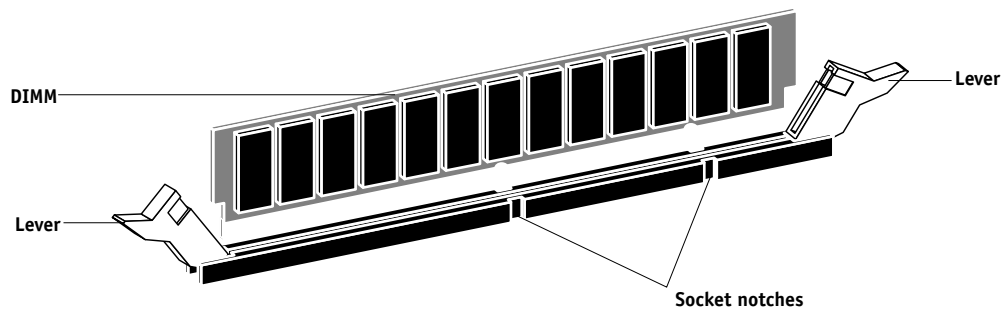

FIGURE 4-10 Releasing a DIMM

2. Slide the DIMM out of the socket.
3. To install a DIMM, slide it into the socket until the levers snap into place.

The DIMM fits the socket only one way. The two notches on the bottom of the DIMM should line up with the notches in the socket.



To avoid bending and flexing the E-700 board, firmly seat the DIMM by pressing from the bottom of the E-700 board as you press the DIMM into its socket.

Make sure that the levers close securely around the ends of the DIMM and that the DIMM is fully seated in its socket.

4. Reassemble the copier and verify functionality as described in "Restoring E-700 functionality after service" on page 4-22 or other documentation.
5. Print a Configuration page to verify the amount of memory.

4 Service Procedures

Battery

The battery on the E-700 board is located at BT. To replace it, use a 3V manganese dioxide lithium coin cell battery (Panasonic CR2032 or equivalent).



CAUTION: There is danger of explosion if the battery is replaced with the incorrect type. Replace only with the same type recommended by the manufacturer. Dispose of used batteries according to the manufacturer's instructions.

ACHTUNG: Es besteht Explosionsgefahr, wenn die Batterie durch eine Batterie falschen Typs ersetzt wird. Als Ersatz dürfen nur vom Hersteller empfohlene Batterien gleichen oder ähnlichen Typs verwendet werden. Verbrauchte Batterien müssen entsprechend den Anweisungen des Herstellers entsorgt werden.

ATTENTION: Il y a risque d'explosion si la pile est remplacée par un modèle qui ne convient pas. Remplacez-la uniquement par le modèle recommandé par le constructeur. Débarrassez-vous des piles usées conformément aux instructions du constructeur.

TO REPLACE THE BATTERY

1. **Locate the battery on the E-700 board (see Figure 4-6 on page 4-8).**
2. **Carefully lift up the clip that holds the battery.**

Use caution when lifting up the clip; excessive force could cause the clip to lose its tension.

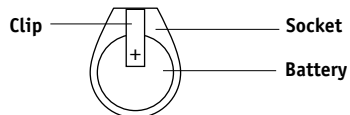

FIGURE 4-11 E-700 battery

3. **Pull the battery out of its socket and release the clip.**
4. **To insert a new battery, slide the battery into the socket under the clip with the positive (+) side facing up.**

Make sure the clip holds the battery securely in the socket.

5. **Reassemble the copier and verify functionality as described in "Restoring E-700 functionality after service" on page 4-22 or other documentation.**

NOTE: When you power on, let the Start-up diagnostics complete, then power off and power on again to initialize the realtime clock.

The date and time of day are lost when the old battery is removed. See the *Configuration Guide* for instructions on entering Server Setup to program the system date and time.

4

Replacing parts of the E-700

CPU fan

An air intake fan attached to the CPU heat sink runs continuously when the copier is on.

TO REMOVE THE CPU FAN

1. Shut down the copier and access the E-700 as described on page 4-3.
2. Remove the CPU fan cable from board connector J27.
3. Using a Phillips screwdriver, remove the two screws that fasten the CPU fan to the CPU heatsink. Set aside the screws so that you can replace them later.

When using the screwdriver, make sure not to apply excessive pressure on the board.

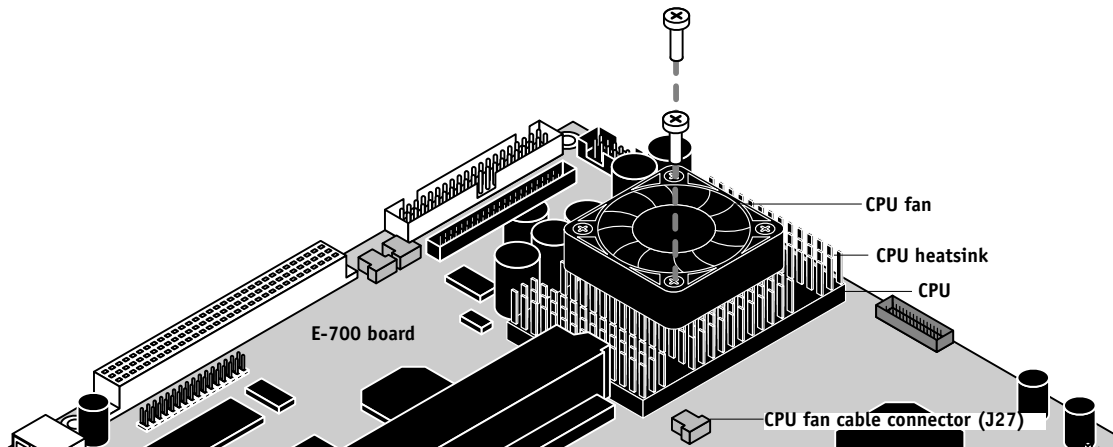

FIGURE 4-12 Removing the CPU fan

4. Remove the CPU fan and set it aside.

TO INSTALL THE CPU FAN

1. Position the CPU fan on top of the CPU heatsink so that the arrow on the fan is pointing to the copier interface board.
2. Attach the CPU fan to the CPU heatsink with the two screws you removed earlier.
When using the screwdriver, make sure not to apply excessive pressure on the board.
3. Connect the CPU fan cable to connector J27.
4. Reassemble the copier and verify functionality as described in "Restoring E-700 functionality after service" on page 4-22.

4

Service Procedures

Exhaust fan

The exhaust fan is mounted on the side of the E-700 pan and pulls warm air out of the E-700. Two arrows on the side of the fan indicate fan rotation and airflow direction. One arrow should point away from the E-700 board. The exhaust fan cable connects to E-700 board connector J25.

TO REMOVE THE EXHAUST FAN

1. Shut down the copier and access the E-700 as described on page 4-3.
2. Remove the video interface board as described on page 4-12.
3. Remove the exhaust fan cable from E-700 board connector J25.
4. Remove the fan cable from the pan cutout.



Carefully cut any tie-wraps that join the fan cable to the power cable and to the standoff for the E-700 board. Avoid cutting either cable.

5. Remove the four screws that secure the exhaust fan to the side of the E-700 pan.
Set aside the screws and fan.

TO REPLACE THE EXHAUST FAN

1. Align the exhaust fan with the four holes in the side of the pan.
Make sure that a direction arrow imprinted on the side of the fan is pointing away from the E-700.
2. Insert the fan cable through the pan cutout.
3. Align the fan and replace the four screws through the fan into the side of the pan.
4. Replace the exhaust fan cable on E-700 board connector J25.



5. Drape the cable low and fully inside the pan to prevent the cable from being cut by the pan cover when you reassemble the E-700.

Tie-wraps can be used to join the fan cable to the power cable and to the lower part of the standoff for the E-700 board.

6. Replace the video interface board as described on page 4-13.
7. Reassemble the copier and verify functionality as described in "Restoring E-700 functionality after service" on page 4-22.

4

Replacing parts of the E-700

Hard disk drive

The factory-installed hard disk drive (HDD) is formatted and loaded with all E-700 software, including operating software, system software, network drivers, and printer fonts. Because the HDD is used to store spooled print jobs, available disk space is displayed on the Info screen. Disk space is also listed on the Configuration Page (see “Printing the Configuration page” on page 2-9).

If you are replacing the HDD, you will need:

- The appropriate System Software CD and documentation
- The latest version of user software (for networked computers that will be printing to the E-700)

Proper handling

Handle the HDD with care:

- Use proper ESD practices when grounding yourself and the E-700.
- Keep magnets and magnetic-sensitive objects away from the HDD.
- Loosening the screws on the top of the HDD voids the warranty.
- Never drop, jar, or bump the HDD.
- Handle the HDD by its sides and avoid touching the printed circuit board.
- Allow the HDD to reach room temperature before installation.

Before you decide that the HDD needs to be replaced, make sure that all cables are connected properly.

If the HDD needs to be replaced, you’ll need to install the system software on the new HDD. Replacement drives are shipped without E-700 system software installed.



Make sure you attach an ESD grounding wrist strap and follow standard ESD (electrostatic discharge) precautions before handling E-700 components.

4 Service Procedures

TO REMOVE THE HDD

1. Print the following from the Functions menu:

- Configuration page —records the customer's current Setup configuration. If you are installing a new drive you will need to reinstall system software. The Setup configuration will be reset to the default configuration when HDD is replaced.
- Font List— details the fonts that are resident on the E-700 HDD. The installed fonts will need to be reinstalled when the HDD is replaced.

2. Shut down the copier and access the E-700 as described on page 4-3.

3. Remove the HDD cable from E-700 board connector J28.

4. Remove the E-700 board from the pan (see "To remove the E-700 board" on page 4-9).

5. With the pan on its side, remove the four screws on the bottom of the pan that secure the HDD (see Figure 4-13).

Hold the HDD with one hand while you remove the screws.

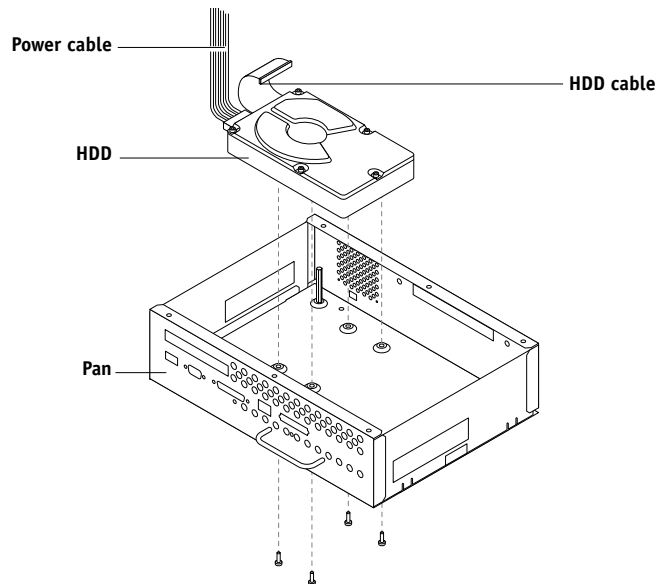

FIGURE 4-13 Replacing the HDD

6. Remove the power cable from the HDD.

7. Remove the HDD from the pan, remove the HDD cable from the HDD, and place the HDD into an antistatic bag.

Do not touch the drive with magnetic objects, such as magnetic screwdrivers. Do not place items near the hard disk drive that are sensitive to magnets, such as credit cards and employee ID cards. See "Proper handling".

4

Replacing parts of the E-700

TO REPLACE THE HARD DISK DRIVE



Make sure you attach an ESD grounding wrist strap and follow standard ESD (electrostatic discharge) precautions before handling E-700 components.

1. **Remove the HDD from the antistatic bag, connect the HDD cable to the HDD, and insert the HDD into the pan.**
2. **Connect the 4-wire connector of the power cable to the HDD.**
The connector is keyed to fit only when properly oriented.
3. **With the pan on its side, align the four holes in the bottom of the HDD with the holes in the bottom of the pan and replace the four screws you removed earlier (see Figure 4-13 on page 4-20).**
4. **Replace the E-700 board (see “To replace the E-700 board” on page 4-10).**
5. **Replace the HDD cable to E-700 board connector J28.**
6. **Reassemble the copier and verify functionality as described in “Restoring E-700 functionality after service” on page 4-22 and other copier documentation.**



Improper connection of the power cable can damage the E-700. See “Checking E-700 internal connections” on page 4-5 including Figure 4-5 on page 4-6.

7. **If you replaced the HDD with a new drive, install system software (see page 4-24). If a startup error occurs when you power on the copier, check E-700 connections. If a startup error still occurs, call your authorized service/support center.**

4 Service Procedures

Restoring E-700 functionality after service

TO RESTORE FUNCTIONALITY

1. Reinstall any boards, cables, connectors, and other parts of the E-700 that you loosened during inspection or service.



Improper connection of the power cable can damage the E-700. See “Checking E-700 internal connections” on page 4-5 including Figure 4-5 on page 4-6.

2. Tighten the screws you loosened during inspection or service.

Make sure all components are in proper alignment as you tighten the screws.



3. Replace the pan cover on the pan, fitting the sides of the pan cover into the tabs.

Make sure all cables are low and fully inside the pan before you replace the pan cover.

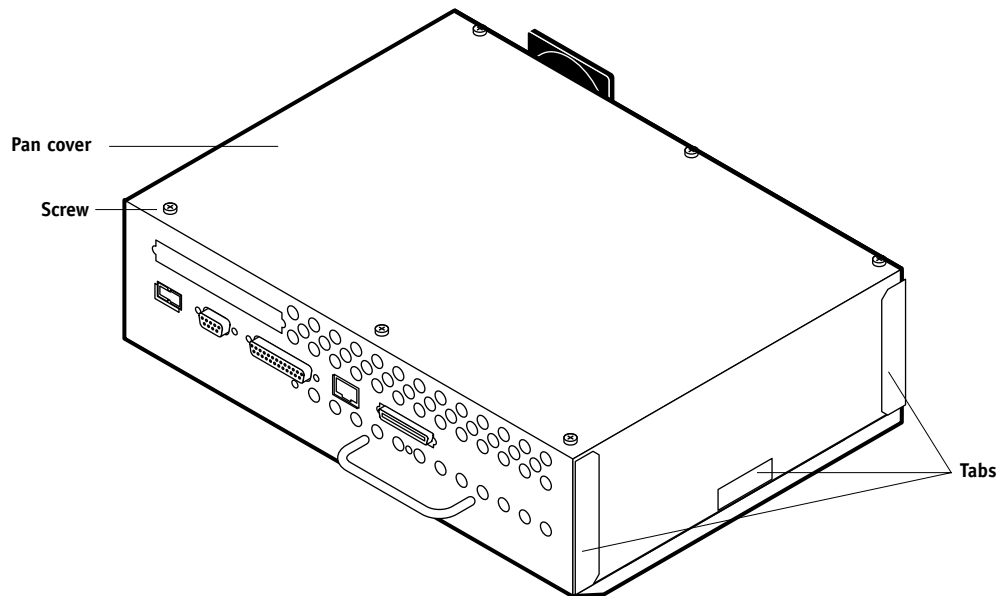

FIGURE 4-14 Replacing the pan cover

4. Install the six screws you removed earlier.
5. Install the E-700 in the I/F unit and reassemble the copier (see “Installing the E-700 in the copier” on page 2-5).
6. Connect any external cables that you removed during inspection or service.

4

Restoring E-700 functionality after service

7. Before you leave the customer site, verify E-700 operation (see Figure 4-15 on page 4-23).

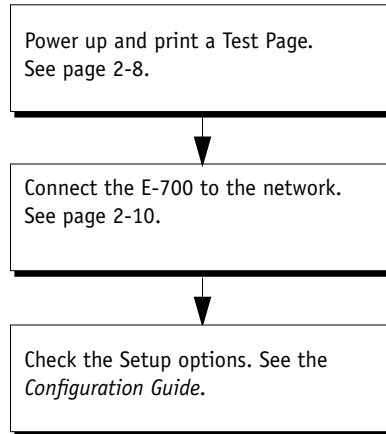

FIGURE 4-15 E-700 connection verification steps

4

Service Procedures

E-700 system software

System is installed from a CD-ROM drive connected to the SCSI interface connector (see page 4-25). The E-700 System Software CD includes the system software and fonts. Use the System Software CD when:

- You replace the E-700 HDD
- You upgrade to a more recent version of the system software

The latest user software must be installed onto all computers that print to the E-700. Using incompatible versions of the system and user software may result in system problems.

System software installation reminders

Keep in mind the following when installing system software:

- **Job Log**—Formatting the HDD to install system software deletes the list of jobs in the Job Log and any jobs in the queues. The network administrator can use Fiery Spooler to save a current list of jobs (not the actual jobs) from the Job Log.
- **Fonts**—Formatting the HDD to install system software deletes all fonts installed on the E-700 HDD. Resident fonts are restored during system software installation. If any additional fonts were downloaded to the E-700, the network administrator can reinstall the fonts using Fiery Downloader.

To determine which additional fonts were downloaded to the E-700, print the font list before you install system software. Any fonts *not listed* after installation will need to be reinstalled. See the *Printing Guide* for more information.

- **Language**—Screens for installing system software are always displayed in English even if the E-700 is configured for another language.
- **Compatibility**—The latest user software should be installed onto all computers that print to the E-700. Using incompatible versions of the system and user software may result in system problems.

4

E-700 system software

Installing system software using the SCSI interface connector

To install system software, you will need an external CD-ROM drive and a SCSI cable to connect the CD-ROM drive to the E-700 SCSI interface connector. Follow the instructions below to attach the CD-ROM drive.

TO INSTALL SYSTEM SOFTWARE

1. Print the following from the E-700 Functions menu:

- Configuration page —records the customer's current Setup configuration. If you are installing a new drive you will need to reinstall system software. The Setup configuration will be reset to the default configuration when system software is installed.
- Font List— details the fonts that are resident on the E-700 HDD. The installed fonts will need to be reinstalled when system software is installed.

2. Power off the E-700. Make sure that the CD-ROM drive is also powered off.

3. Attach the CD-ROM drive SCSI cable to the E-700 SCSI interface connector.

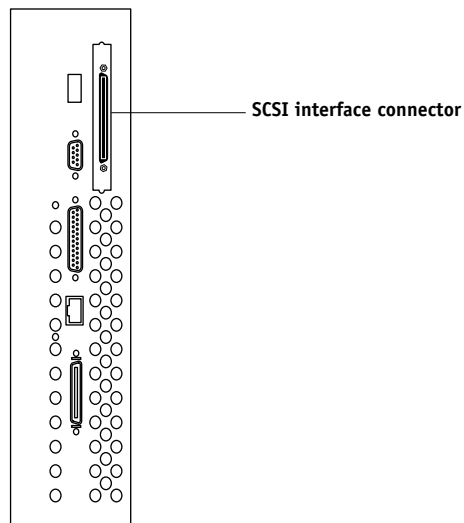

FIGURE 4-16 SCSI interface connector

4. Power on the CD-ROM drive and insert the System Software CD once the drive is free of activity.

4

Service Procedures

5. Power on the E-700; "Please Wait..." will flash on the Operation Panel as the E-700 boots from the System Software CD. System software installation will begin immediately.

Please wait . . .

6. Wait as the Operation Panel displays "Copying from CD". The Operation Panel will also show "Copied xxxxxK", with xxxxx increasing as the installation proceeds.

NOTE: System software installation will take approximately 35 minutes using a 2X CD-ROM drive.

Copied xxxxxK

7. When the installation file has completely copied from the CD, "Copying Complete, Please Wait..." will appear.

Copying Complete
Please Wait . . .

8. The System Software CD will be ejected from the CD-ROM drive when "Remove CD" is displayed.

Remove CD

9. After the System Software CD is ejected, "Installing System, Do Not Power Off" appears on the Operation Panel. Do not press any keys or power the E-700 off when this screen is displayed.

Installing system
Do not power off

10. When the language selection is then displayed on the LCD, select the desired language.
11. Once the desired language has been selected, the system will boot up using that language.
12. After the system has started up completely, power it off and remove the attached CD-ROM drive, then power the system back on.
13. The system is now ready for customer use.

5

The troubleshooting process

Chapter 5: Troubleshooting Procedures

This chapter focuses on the troubleshooting process and identifies the source of common problems that may occur with the Color Controller E-700 assembly and suggests ways of correcting them.

The troubleshooting process

The troubleshooting process is designed to eliminate the most obvious causes of failure before progressing to more complex issues. “Where problems occur” on page 5-2 gives an overview of the E-700 components and indicates areas most likely to require troubleshooting.

If the E-700 fails to complete its Start-up sequence and the E-700 does not reach the Idle screen, the most likely cause is a loose cable or board connection. See “Checking E-700 internal connections” on page 4-5.

- Try a phone check before you go to the customer site.
“Before you go to the customer site” on page 5-3 suggests areas you should check out before making a service call to the customer site. With a phone call, you can find out if the problem is a simple operating failure or a failure caused by a network or configuration change. You can ask the customer to check for loose cables on the side of the copier and loose connections at a power strip or outlet.
- Check for obvious causes of problems.
“Preliminary on-site checkout” on page 5-4 takes you through the initial visual checkouts you should make when you arrive at the customer site. You should check the Operation Panel for an error message and see if the LEDs indicate an error condition. Then inspect the copier externally and internally for the most common problems, such as loose or faulty cables.
- Check network connections.
“Checking network connections” on page 5-9 provides guidelines for checking the network connections between the copier and the computers to which it is connected as well as information on several printing problems.

5 Troubleshooting Procedures

Where problems occur

The E-700 as a built-in print server for the copier is generally part of a configuration like the one shown in Figure 5-1. Problems may occur in one of the following areas:

- The interface between the E-700 board and the copier
- The interface between the E-700 and computers on the same network
- The board or copier itself

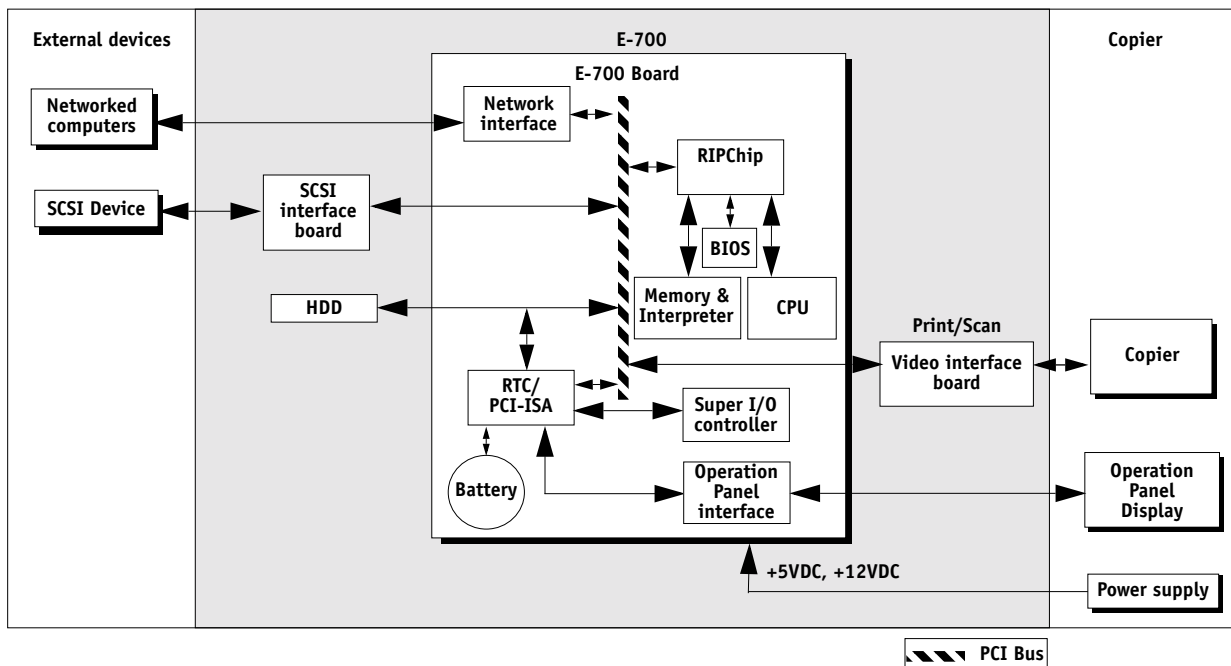

FIGURE 5-1 E-700 functional diagram

This chapter does not attempt to provide troubleshooting information for extensive networks. You should refer problems in these areas to the appropriate service departments and network administrators.

5

Before you go to the customer site

Before you go to the customer site

Before you make a service call to a customer site, talk to the customer on the phone, and check out the following items:

1. Does the copier work?

If the copier works, but the user cannot print the E-700 Test Page, have the customer check the Message LED and any error messages in the Operation Panel. If the E-700 Operation Panel reports an error, check the copier interface cable between the E-700 and the copier.

2. Is the failure caused by a simple operating problem?

- Is there a printing problem?
 - Does the E-700 Test Page fail to print?
 - Does the E-700 fail to respond to a print command?
 - Does printing seem to take a long time?
 - Is print quality poor?
 - Does the E-700 fail to appear in the list of printers?
- Has the customer noted any error messages on the copier Operation Panel?

If the answer to any of these questions is yes, refer the customer to the Troubleshooting Appendix in the *Printing Guide*.

If the customer has followed the corrective actions in the *Printing Guide* and has failed to solve the problem, be prepared to make a service call. Keep a log of the failures and messages the customer has observed.

3. Has the customer made any network changes?

If network changes have occurred, request that the customer's network administrator verify the E-700 network requirements.

4. Is the user having printing problems with a particular image file?

If there are problems with files from particular applications, the user may be more successful using different print settings.

If your telephone call fails to clear up the problem, proceed to the next phase, the preliminary on-site checkout.

5 Troubleshooting Procedures

Preliminary on-site checkout

Your goal in the preliminary on-site checkout is to eliminate obvious problems, such as loose or missing cables and connectors.

Checking connections

Before you remove the copier cover to inspect cables:

- Check that external interface cables are plugged into the proper connectors at the side of the copier.

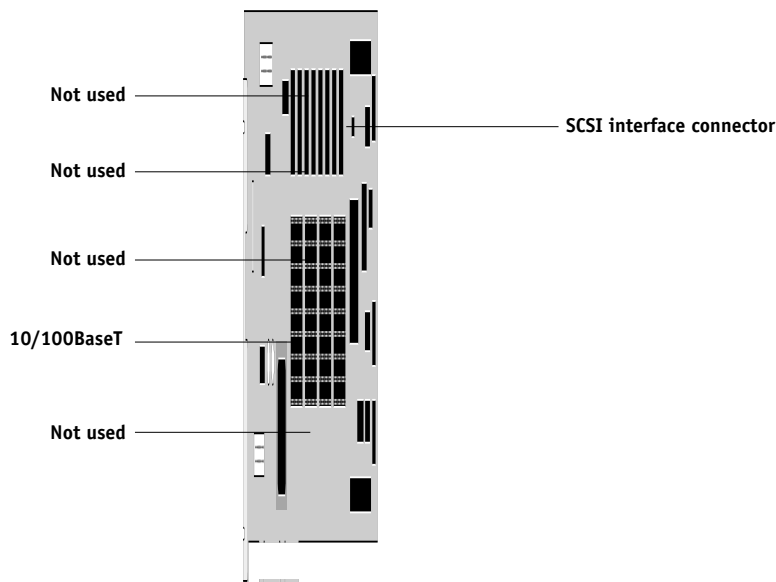

FIGURE 5-2 External connectors

- Make sure the power cable is plugged into the wall outlet and that the copier is powered on.
- Make sure the copier power supply cable is attached to the copier and to the E-700 board connector J20.
- Make sure the Operation Panel cable is attached to the copier and to the E-700 video board.

Also, see “Checking E-700 internal connections” on page 4-5. See other documentation for guidelines when disassembling, checking, and reassembling the copier. If all the connectors are in place and the problem still exists when the copier is powered on, then proceed to the next stage of troubleshooting.

5

General E-700 system errors

General E-700 system errors

When you start up the system or when you install system software, you may encounter error conditions that are not reported during the Start-up diagnostics. Table 5-1 lists some of these error conditions and suggests corrective action.

When you first encounter any of these error conditions, power off the copier and inspect for an obviously loose part or cable. Then check other components as suggested below. For service procedures, refer to Chapter 4.

TABLE 5-1 General E-700 system error conditions and messages

Symptom	Probable cause	Suggested action
E-700 does not start up.	Power cable is not properly connected.	<ul style="list-style-type: none">• Make sure that the power cable is connected between the copier and the E-700 at J20 (see “Checking E-700 internal connections” on page 4-5).
	Power supply has failed.	<ul style="list-style-type: none">• Replace the copier power supply.
E-700 starts up but CPU fan is not working or overheating.	CPU fan is not properly connected.	<ul style="list-style-type: none">• Check CPU fan connection to E-700 connector J27 (see “CPU fan” on page 4-17).• If problem persists, replace the CPU fan.
CPU fan is working but does not blow air away from the E-700.	CPU fan is installed upside down.	<ul style="list-style-type: none">• Remove the CPU fan and reinstall it in the proper orientation (see “CPU fan” on page 4-17).
Buttons do not work on the E-700 Operation Panel.	Connection to the Operation Panel is faulty or the Operation Panel is bad.	<ul style="list-style-type: none">• Check cable connection to E-700 Operation Panel and to the E-700 connector on the video interface board.
	Faulty chip on the E-700.	<ul style="list-style-type: none">• If the problem persists, you may have to replace the E-700 assembly.
Nothing appears on the E-700 Operation Panel when the copier is powered on	Connections to the Operation Panel are faulty or the Operation Panel is faulty.	<ul style="list-style-type: none">• Check the cable connection to the copier and E-700 connector (see “Checking E-700 internal connections” on page 4-5).• Power on the copier and the E-700.• If the problem persists, replace the cable.• If the problem still persists, replace the E-700.
	Faulty power supply.	<ul style="list-style-type: none">• Check power supply cable connections to the E-700 (see “Checking E-700 internal connections” on page 4-5).• If problem persists, replace the copier power supply.
	Bad DIMM connections	<ul style="list-style-type: none">• Open the E-700 to make sure that the DIMMs are seated correctly.• If the problem persists, try switching the DIMMs to other slots.• If problem still persists, replace DIMMs.

5 Troubleshooting Procedures

TABLE 5-1 General E-700 system error conditions and messages (Continued)

Symptom	Probable cause	Suggested action
Problem when installing system software.	No CD is inserted or the wrong CD is inserted in the CD-ROM drive connected to the E-700.	<ul style="list-style-type: none">• Check the CD inserted in the CD-ROM drive.
	Faulty System Software CD, HDD, or CD-ROM drive.	<ul style="list-style-type: none">• Check HDD connections.• If the problem persists, use a tested CD-ROM drive cable.• If the problem persists, try installing software using a different System Software CD.• If the problem still persists, you may need to replace the HDD or use a different CD-ROM drive.

5

Video board diagnostics

Video board diagnostics

One of the menu items in the Functions screen on the E-700 Operation Panel is Run Diagnostics. Select Run Diagnostics to run Video Diagnostics if you suspect there may be a problem with the E-700 video interface board (for example, the print quality of output is poor) Video Diagnostics loops data internally, comparing data sent with data received to make sure no errors have occurred.

TO RUN VIDEO DIAGNOSTICS

1. Power on the copier. Once the E-700 has reached the Ready screen, press the Menu key to view the Functions menu.
2. Select Run diagnostics then Video Diagnostics. The test will start immediately.

Functions.
Print Pages

Press the ▼ key 3 times

Functions.
Run Diagnostics

Press the Set key to select

Diagnostics
Video Diags

Press the Set key to select

3. If "Video Diags passed" appears, press the Cancel key to return to the Functions menu.
4. If "Video Diags failed" appears, then to fix the problem you may have to replace the E-700 board.

5 Troubleshooting Procedures

Printing the Test Page

If the Test Page does not print at all or has a low-quality image, the E-700 board or the copier interface cable may be faulty or the copier may not be functioning properly.

TO PRINT THE TEST PAGE

1. Power on the copier and allow it warm up.

Messages appear on the E-700 Operation Panel as the E-700 runs through its Start-up diagnostics.

2. At the Ready screen, press the Menu key once to display the Functions menu.

3. Select Print Pages then Test Page.

Press the Set key to select the option displayed. Press the down arrow key to display each option.



The E-700 sends the Test Page to the copier and displays the RIP and Print status screens so you can monitor the job.

4. Examine the quality of the Test Page from the copier.

If the Test Page prints successfully with good image quality, then the E-700 print engine is functional and the connection between the E-700 and the copier is good.

5

Checking network connections

Checking network connections

Printing problems may arise if the network hardware or software is not set up properly or does not match network settings on the E-700. Problems may also arise when printing from a specific application or printing a particular file.

Most of these problems show up as printing problems and do not necessarily indicate a E-700 malfunction. The customer's network administrator can eliminate many printing problems without requiring you to make a service call. The network administrator deals with:

- Print device error conditions
- Network connection problems that result in the copier not appearing in the list of printers on the customer's computers

NOTE: If the copier does not appear in the list of printers on the network, there may be another device on the network with the same Ethernet hardware address.

- Conflicting network settings in Setup and on the customer's computers
- Printing problems caused by inappropriate Setup options
- Application-specific printing errors caused by missing or incorrectly installed printer description files

5

Troubleshooting Procedures

Printing to the E-700

If the customer can print a E-700 Test Page but cannot print a job from a computer on the network, you may have to make a service call. However, first make sure the network administrator has done the following:

- Checked all components of the network including cables, connectors, terminators, network adapter boards, and network drivers.
- Activated the network and used it to communicate with other printers.
- Checked the corrective actions listed in “E-700 Error Messages” in the *Printing Guide*.
- Confirmed that the applicable network settings in Setup (such as AppleTalk zone, IP address, Subnet mask, and Gateway address) match the settings used in the network.

When you make a service call, check the E-700 faceplate at the side of the copier to make sure that the appropriate network connection is in place.

Print quality problems are difficult to trace. Before you try to troubleshoot print quality problems, print a Test Page to make sure that the copier does not need servicing or adjusting. Also, make sure the correct paper is being used in the copier.

NOTE: EPS file generation is not completely standardized among applications. Some users may encounter problems while printing certain EPS files.

5

Checking network connections

General printing problems

If the copier is working properly, and the corrective actions listed in the *Printing Guide* have not solved a printing problem, check the items listed in Table 5-2.

TABLE 5-2 Printing problems - General

Error Message or Condition	Probable cause	Suggested action
E-700 Test Page quality is poor.	Copier and E-700 require calibration.	<ul style="list-style-type: none"> • Perform copier calibration (see the Copier service documentation for more information). • Perform E-700 AutoCal (see the <i>Color Guide</i> for information).
E-700 appears in the list of printers on the customer's workstation, but certain jobs do not print.	A PostScript error	<ul style="list-style-type: none"> • Make sure Print up to PostScript Error in Setup is set to Yes. Check for error messages on the E-700 output.
	An application problem	<ul style="list-style-type: none"> • Try printing a job from a different application to determine if the problem is associated with a particular application.
A print job stalls.	A PostScript or application error	<ul style="list-style-type: none"> • Cancel the E-700 print job. • If this fails to clear the problem, reboot the E-700.
Printing stops after one or a few pages.	Faulty DIMM(s)	<ul style="list-style-type: none"> • Reboot the copier and allow the Start-up diagnostics to run. If faulty DIMMs are detected, replace the faulty DIMMs. • If this fails to clear the problem, try reinstalling the system software.
Color quality is uneven.	A copier problem	<ul style="list-style-type: none"> • Use the copier to copy a sample copier test page. If the quality is not good, service the copier.
	A file or application problem	<ul style="list-style-type: none"> • Print the E-700 Test Page. • If the quality of the E-700 Test Page is good, there may be a file or an application problem.
Print quality is poor.	A missing or outdated printer description file <hr/> The application cannot find the appropriate printer description file.	<ul style="list-style-type: none"> • Make sure the appropriate printer description file is installed. See <i>Getting Started</i> for a list of printer files used by various applications.
Job never prints and the RIP screen is active.	The network cable was plugged in when the copier was already on.	<ul style="list-style-type: none"> • Turn off the copier and turn it back on again. • Make sure Setup is configured correctly.

A

Hardware features

Appendix A: Specifications

This chapter summarizes the hardware and networking features of the Color Controller E-700.

Hardware features

- 366MHz Intel Celeron CPU
- 256MB memory
- SCSI interface connector for attaching a CD-ROM drive
- Adobe PostScript Level 3
- Battery—3V manganese dioxide lithium coin cell (Panasonic CR2032 or equivalent)

Networking and connectivity

The E-700 has the following networking features:

- Supports AppleTalk, TCP/IP, and IPX protocols simultaneously
- RJ-45 port for twisted pair (10BaseT/100BaseTX) network connection

User software

A complete description of E-700 user software is provided in *Getting Started*. For optimal E-700 performance, current versions of the user software should be maintained on every network computer that might print to the E-700.

Safety and emissions compliance

The E-700 board has been certified to meet or surpass the following standards:

Safety approvals

- UL, C-UL
- EN 60950 (TÜV Bauart geprüft)

EMI approvals

- FCC Class B
- VCCI Class A
- EN 55022 Class B
- AS/NZS 3548 Class B
- EN 50082-1
- AS/NZS 42521

A Specifications

Output voltage



On the E-700, the SCSI and USB connectors output +5V DC. The other external connectors on the E-700 including the copier interface connector have no output voltage (see Figure A-1).

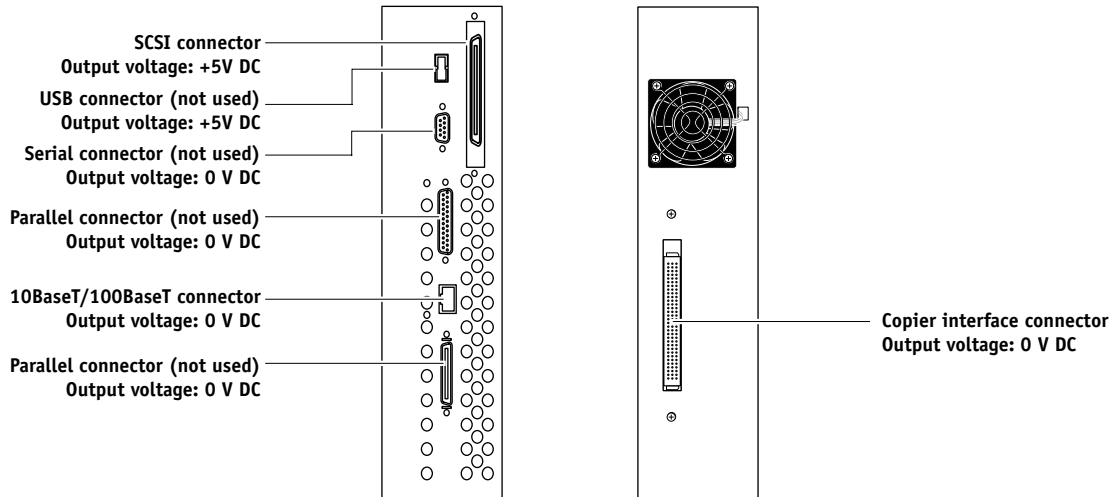

FIGURE A-1 E-700 output voltage

PTC Rating

R158, R135, R159

Rated hold current 0.75A

Rated trip current 1.5A

Max. voltage +15V DC

B Installation Procedure

Appendix B: Controller Interface Type F

The Controller Interface Type F kit must be installed before installing the E-700.

This appendix provides the *Controller Interface Type F Installation Procedure*.

NOTE: In this procedure, the term “controller box” refers to the E-700 and the term “interface unit” refers to the “I/F unit”. Also note that step 17 is covered in detail in Chapter 2 “Installation.” In particular, see “Installing the E-700 in the copier” on page 2-5.

Installation Procedure

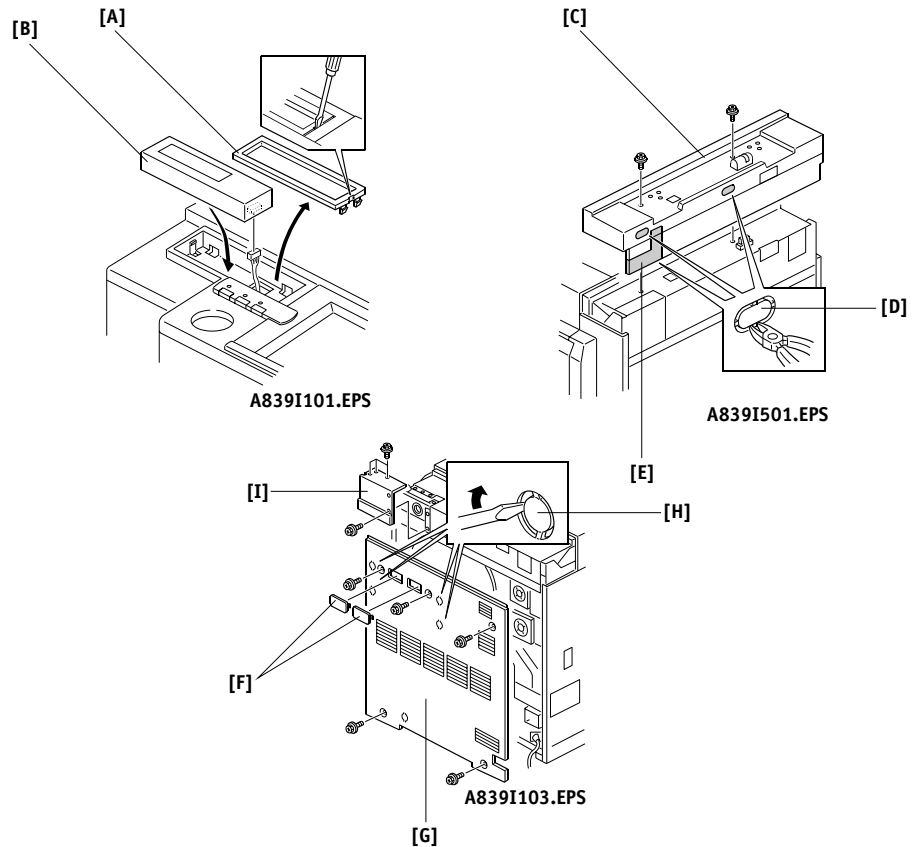

Unplug the copier power cord before starting the following procedure.

NOTE: Remove the platen cover or ADF if it is installed.

1. Remove the cover plate [A] from the Operation Panel with a small blade screwdriver. Then, install the controller LCD panel [B] on the Operation Panel (1 connector).
2. Remove the upper rear cover [C] from the copier (2 screws) and cut out the 2 plastic caps [D] and harness inlet plate [E] from the upper rear cover with cutting pliers.

B

Controller Interface Type F

3. Remove the 2 plastic caps [F] from the rear cover [G]; then, remove the 4 metal caps [H] with a blade screwdriver as shown.

NOTE: Place a hand over the metal caps as you pry them out in order to control their trajectory.

4. Remove the rear cover (5 screws) and shield cover [I] (4 screws).

(The shield cover will not be used any more.)

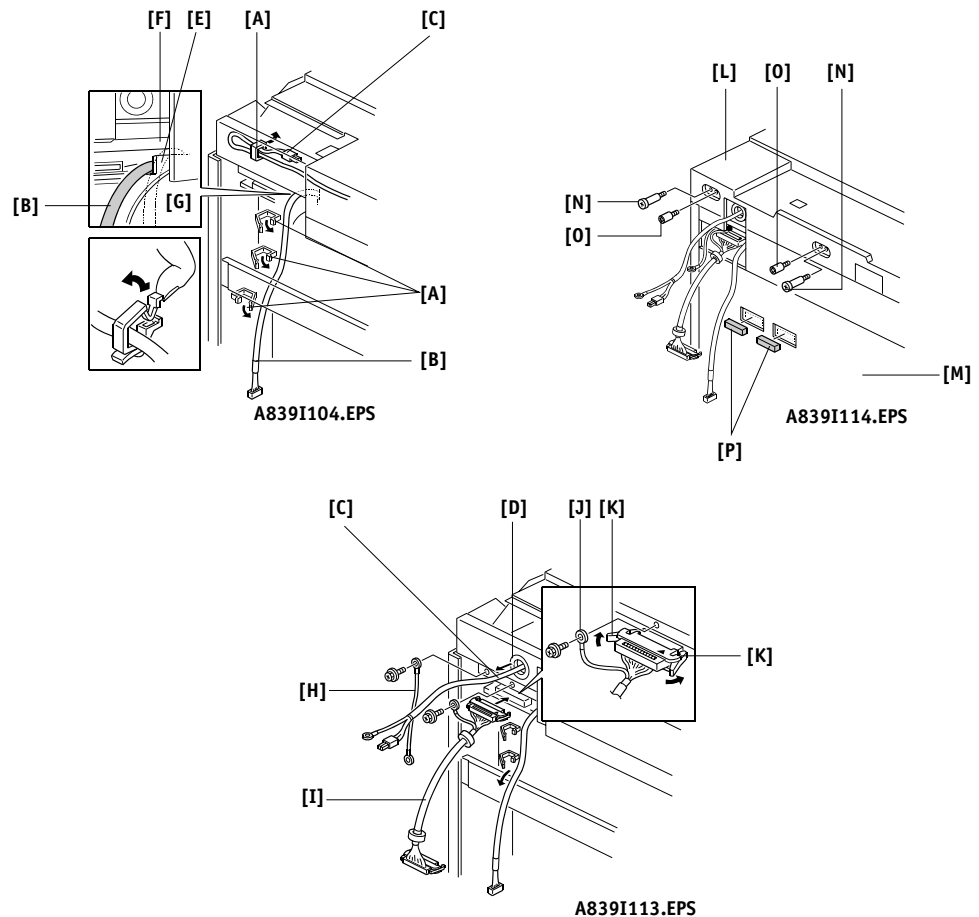

5. Open 4 clamps [A] as shown, pull out the harnesses [B] & [C], and close the clamps. Then, put the harness [C] through the harness bushing [D].

NOTE: Make sure that the harness [B] is routed as shown. If it is routed in between the bracket [E] and stay [F] as shown in dotted line, the harness may touch the flywheel [G].

6. Secure the grounding wire [H] (1 screw). (220 ~ 240 V version only)

B Installation Procedure

7. Connect the interface harness [I] (connector which has a grounding wire) to the LD control board and secure the grounding wire [J] as shown (1 screw).

NOTE: Insert the connector firmly so that the two lock hooks [K] are engaged as shown.

8. Reinstall the upper rear cover [L] and the rear cover [M] with the three harnesses (3 harnesses and grounding wire on 220 ~ 240 V version) outside the machine as shown.

9. Secure the hook stud screws [N] and stand-off stud screws [O] (2 each).

10. Peel off the seal of two-sided tape and attach the 2 conductive gaskets [P] as shown.

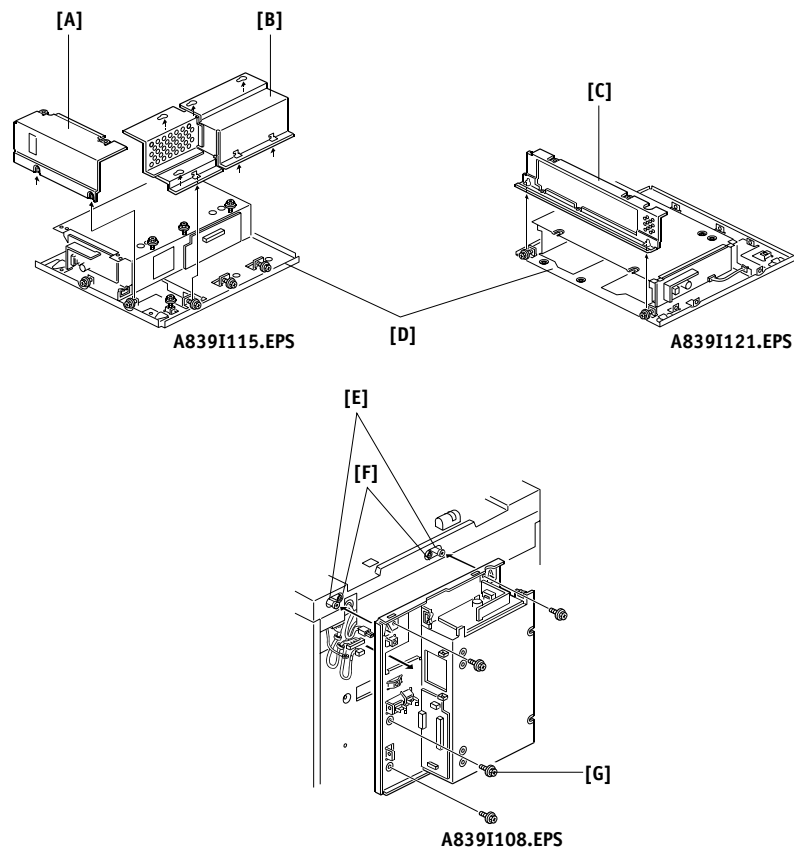

11. Loosen the screws securing the upper shielding cover [A], left shielding cover [B], and right shielding cover [C]; then, remove them from the interface unit [D].

12. Put the 3 harnesses (3 harnesses and grounding wire on 220 ~ 240 V version) through the cut-out of the interface unit and hook the interface unit on the stud screws [E]. Then, secure the 3 screws (2 screws go into the stand-off stud screws [F]) and 1 grounding screw [G].

B

Controller Interface Type F

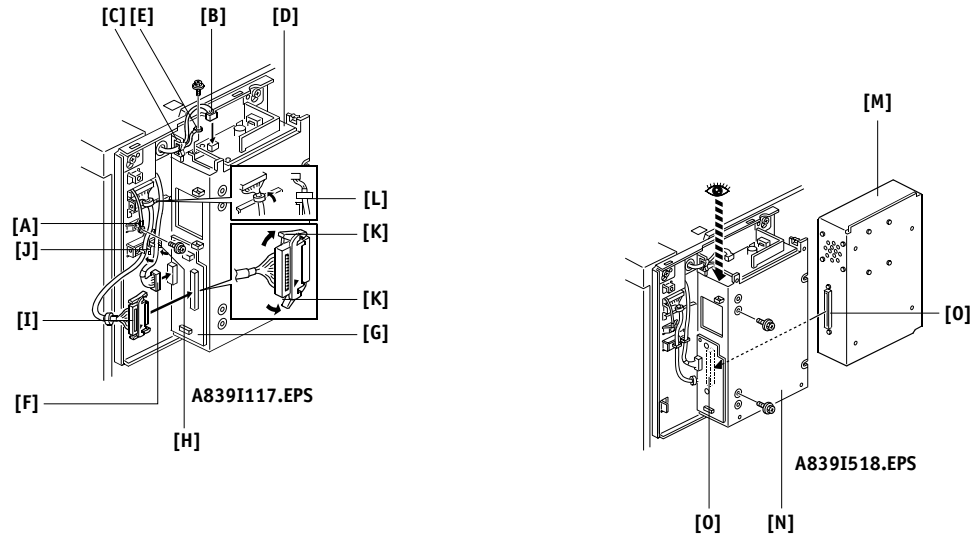

13. Secure the grounding wire [A] (1 screw). (220 ~ 240 V version only)
14. Secure the harness [B] in the clamp [C] and connect the 2P connector on the power supply board [D] of the interface unit. Then, secure the grounding wire [E] as shown (1 screw).
15. Connect the 24P connector [F] on the interface board [G] and secure the harness in the clamp [H].
16. Connect the interface harness [I] to the interface board and secure the harness in the clamp [J].

NOTE: Insert the connector firmly so that the lock hooks [K] are engaged as shown.
Make sure that the ferrite core [L] is placed in the space of the cut out of the interface unit as shown.
17. Insert the controller box [M] in the interface unit [N] (2 screws) (Look down through the top of the interface unit to see the connectors. The controller box needs to be pulled up slightly to engage the connectors smoothly.)

NOTE: Make sure that the connectors [O] are firmly connected.

B

Installation Procedure

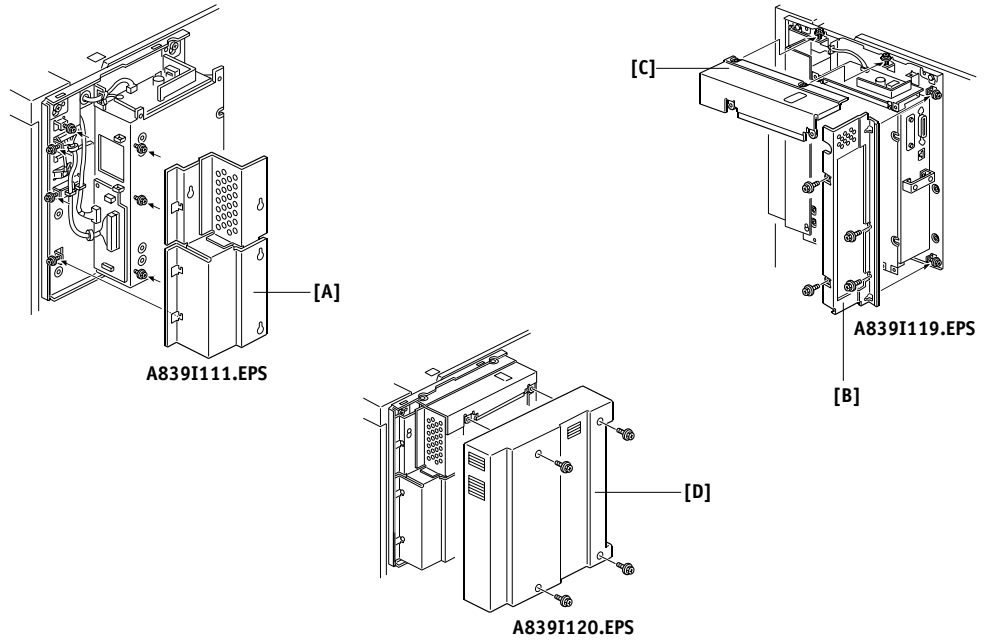

18. Reinstall the left shield cover [A] (7 screws).
19. Reinstall the right shield cover [B] (6 screws) and upper shield cover [C] (2 screws).
20. Install the interface unit cover [D] (4 screws).
21. See the *Configuration Guide* for Setup information.

Index

Numerics

10/100BaseT 2-10

A

activity indicators

error 3-2

printer/scanner 3-2

printing/processing 3-2

AppleTalk 1-1

B

banks, DIMM 4-15

battery 4-16, A-1

BIOS 4-25

C

cables

checking 5-4

connections 4-5

HDD 4-21

reseating 4-5

cancel key 3-2

CD

System Software 4-19, 4-24

User Software 1-3

checking

cables 4-5, 5-4

network connections 5-9

chips

CPU 1-2

Rip 1-2

Color Separation and Gray Scale 2-2

Configuration page 2-9, 3-4

connecting

to the network 2-10

connectors

copier interface 2-5–2-6, 4-5

network 2-10

SCSI A-2

twisted pair (10/100BaseT) 2-10

USB A-2

Controller Interface Type F kit xi, 2-2

copier interface connector 2-5–2-6, 4-5

CPU 1-2

CPU fan 4-17

D

damage, reporting *xiii*

DIMMs

banks 4-15

configurations 1-2, 4-15

removal and replacement 4-15

disk space 4-25

down arrow key 3-2

E

ECP mode 4-25

EMI approvals A-1

enter key 3-2

EPS files, printing 1-3

error light 3-2

errors

installing system software 5-5

system 5-5

ESD (electrostatic discharge) safety

precautions *xiii*

Ethernet address 5-9

exhaust fan 4-18

F

fan

CPU 4-17

fans

exhaust 4-18

Fiery Downloader 1-3

Fiery WebTools 1-4

Font List option 3-4

Functions menu

Configuration page 3-4

Font List 3-4

Help Map 3-4

Job Log 3-4

Print Pages 3-4

Reboot Server 3-4

Resume Printing 3-4

Suspend Printing 3-4

Test Page 3-4

G

Gray Scale 2-2

Index

H

- hard disk drive
 - proper handling 4-19
 - removal 4-19, 4-21
 - system software 4-19
- hardware specifications A-1
- Help Map 3-4

I

- Install Software 3-5
- IP address *xiii*
- IPX (Novell) 1-1

J

- Job Log
 - option in Functions menu 3-4
 - printing 3-4

K

- keys
 - cancel 3-2
 - down arrow 3-2
 - enter 3-2
 - left arrow 3-2
 - menu 3-2
 - printer/scanner 3-2
 - right arrow 3-2
 - up arrow 3-2

L

- LAN (local area network) *xiii*
- LEDs
 - error 3-2
 - printer/scanner 3-2
 - printing/processing 3-2
- left arrow key 3-2

M

- Media package 2-2
- menu
 - Start up 3-5
- menu key 3-2
- Menu Map 3-4

N

- network connections
 - checking 5-9
 - twisted pair (10/100BaseT) 2-10
- networks
 - connecting to 2-10
 - Novell (IPX) 1-1
 - supported 1-1, A-1
- Novell (IPX) networks 1-1

O

- on-board
 - battery 4-16
 - DIMMs 4-15
- Operation Panel
 - definition *xii*
 - touch panel display 3-3
 - troubleshooting 5-5

P

- PostScript files, printing 1-3
- precautions *xiii*
- printer mode 3-3
- printer/scanner
 - activity indicator 3-2
 - key 3-2
- Print Font List option 3-4
- Print Help Map option 3-4
- printing
 - Configuration page 3-4
 - Font List 3-4
 - Help Map 3-4
 - Job Log 3-4
 - pages 3-4
 - problems 5-10
 - test page, copier 2-3
 - Test Page, server 2-8, 3-4
- printing/processing light 3-2
- Print Pages option 3-4

Index

R

Reboot Server option 3-4
Reboot System 3-5
reseating connections 4-5
Resume Printing option 3-4
right arrow key 3-2
RipChips 1-2
RIP-While-Print 1-3
Run Diagnostics option 3-4
Run Setup 3-5

S

safety approvals A-1
screens 2-8
 Start up 3-5
select, using the enter key 3-2
service calls
 tools required *xiv*
Setup, accessing 3-3
software, user 2-1–2-2
specifications, hardware A-1
Start System 3-5
Start up menu 3-5
Suspend Printing option 3-4
system errors 5-5
system software installation reminders 4-24

T

TCP/IP 1-1
test page, copier 2-3
Test Page, server 2-8, 3-4
tools required for service *xiv*
troubleshooting
 Operation Panel 5-5
twisted pair (10/100BaseT) 2-10

U

up arrow key 3-2
user software 2-1–2-2
User Software CD 1-3
User Software contents 1-3

V

voltage A-2

W

WebTools 1-4

